

Robot à roues Mecanum

Robot à roues Mecanum

Qu'est-ce que Mecanum Wheel?

- La roue Mecanum est une roue omnidirectionnelle qui permet au véhicule robotique de se déplacer de chaque côté et le mouvement général avant et arrière. Bengt Erland Ilon a développé l'idée de roue Mecanum lorsqu'il était employé comme ingénieur dans une entreprise en Suède. Il a breveté l'idée aux États-Unis le 13 novembre 1972. L'autre nom répandu est la roue suédoise ou roue Ilon, d'après le nom du fondateur.

Conception du robot à roues Mecanum

La roue Mecanum est centrée sur une roue infatigable qui est reliée obliquement à toute la circonférence de sa jante avec un jeu de rouleaux externes caoutchoutés. Habituellement, ces ensembles de rouleaux externes caoutchoutés ont chacun un axe de rotation par rapport au plan de roue autour de 45° et avec la ligne d'axe autour de 45° .

Dans chaque robot de roue Mecanum, sa roue a son groupe motopropulseur et est indépendamment de type non directionnel. Le groupe motopropulseur est chargé de générer une force de propulsion qui maintient un angle de 90° avec l'axe du rouleau pendant le mouvement de rotation qui peut être divisée en ses composantes vectorielles longitudinales et transversales.

Principe de commande des roues mecanum

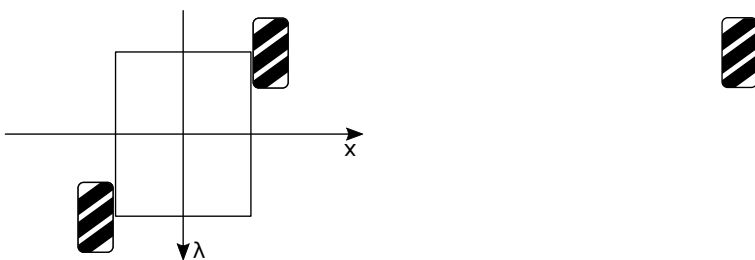

La configuration typique d'un robot à roues Mecanum a une disposition à quatre roues, ce qui est

évident dans un exemple de robots mobiles omnidirectionnels appelé URANUS. Il a des rouleaux latéraux gauche et droit alternés avec des axes parallèles à la diagonale du châssis du véhicule au sommet de la roue. L'un des robots à roues Mecanum: URANUS est illustré ci-dessous.



Les robots à roues Mecanum pour se déplacer avec des exigences de vitesse minimales. Par exemple:

- Conduire les 4 roues à la même vitesse dans la même direction peut conduire à un mouvement d'avance / recul, car les vecteurs de force longitudinale s'additionneront, bien que les vecteurs transversaux s'annulent.
- Entraînement (toutes à la même vitesse) les deux roues dans un sens d'un côté et de l'autre dans le sens opposé. Cela se traduirait par la rotation stationnaire du véhicule lorsque les vecteurs transversaux s'annulent tandis que les vecteurs longitudinaux les vecteurs s'apparient pour produire un couple autour de l'axe vertical central du véhicule.
- Pour vous déplacer latéralement, faites tourner les roues diagonales dans le même sens à la même vitesse et les deux autres roues diagonales seront à l'opposé. Cela entraîne l'ajout de vecteurs transversaux tout en annulant les vecteurs longitudinaux.

Les combinaisons de différents types de mouvements indépendants des roues dans le robot à roues Mecanum, aidées avec une certaine quantité de rotation, facilitent le mouvement du véhicule dans toutes les directions possibles.

Applications du robot à roues Mecanum

Le mouvement omnidirectionnel et la maniabilité extrême dans les environnements encombrés fournis par Mecanum Wheeled Robot ont trouvé leurs applications dans le domaine suivant:

- Le robot à roues Mecanum est utilisé dans diverses activités militaires et missions de recherche et de sauvetage.
- Mecanum Wheeled Robot est également utile dans les explorations planétaires, par exemple MarsCruiserOne, qui est un rover conceptuel habitable pour les futures missions spatiales.
- Mecanum Wheeled Robot est également utilisé dans les opérations minières, ce qui nécessite une bonne mobilité dans les espaces confinés.
- Les chariots élévateurs robotisés à roues Mecanum sont utilisés pour le transport de marchandises pour sa mobilité efficace et la gestion des espaces d'entrepôt.

- Les robots à roues Mecanum sont utilisés dans des projets de fauteuils roulants innovants, par exemple OMNI, car Mecanum Wheeled Robot facilite une mobilité élevée dans un environnement complexe et des degrés plus élevés d'indépendance.

Calculs savants

6239 J bEdho		Standard	Omni	Mecanum
kinematics	V_f	$\omega \cdot r$	$\omega \cdot r \cdot \sqrt{2}$	$\omega \cdot r$
	V_r	-	$\omega \cdot r \cdot \sqrt{2}$	$\omega \cdot r$
	V_d	-	$\omega \cdot r$	$\omega \cdot r / \sqrt{2}$
force	F_f	$4\tau / r$	$4\tau / (r\sqrt{2})$	$4\tau / r$
	F_r	-	$4\tau / (r\sqrt{2})$	$4\tau / r$
	F_d	-	$2\tau / r$	$2\tau\sqrt{2} / r$

The three columns are for standard, omni, and mecanum 4-wheeled vehicles, respectively. The omni vehicle's wheels are mounted at 45 degrees. All wheels same diameter. The first three rows are vehicle velocity: forward, strafe, and diagonal, for a given wheel speed ω (radians/sec)¹. The second three rows are vehicle total pushing force: forward, strafe, and diagonal, for a given wheel torque τ . These last three rows assume a) frictionless mecanum and omni roller bearings, and b) sufficient traction to support the floor reaction forces.

Ratio values: for the same wheel speeds, a omni vehicle goes 41% faster than mecanum; for the same wheel torque, mecanum vehicle has 41% more pushing force than omni².

¹ Only for wheels as presented in this diagram.
² The 41% ratio is only for the same wheel diameter and torque as presented in this diagram.

Cinématique d'une voiture à roue mecanum

Projet IMA 4 : Commande d'un robot mobile holonome et manipulateur

Modelisation_Mathematique_Mecanum.pdf

Arduino roue mecanum

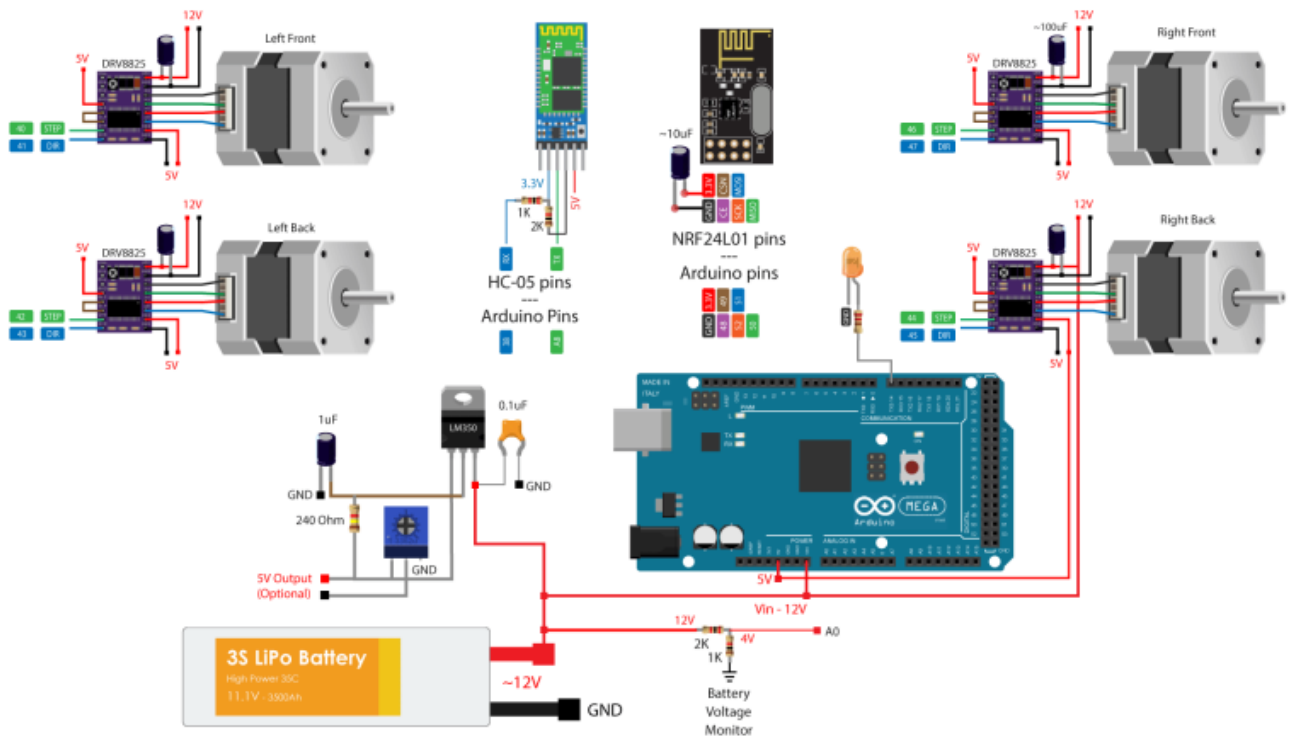

Programmes

rouemecanumarduino.ino

[rouemecanumarduino.ino](#)

```
// à Tester ?  
  
/*  
   === Arduino Mecanum Wheels Robot ===  
   Radio control with NRF24L01  
   by Dejan, www.HowToMechatronics.com  
   Libraries:  
   RF24, https://github.com/tmrh20/RF24/  
   AccelStepper by Mike McCauley:  
   http://www.airspayce.com/mikem/arduino/AccelStepper/index.html  
*/  
  
#include <SPI.h>  
#include <nRF24L01.h>  
#include <RF24.h>  
  
#include <AccelStepper.h>  
  
RF24 radio(48, 49); // nRF24L01 (CE, CSN)
```

```
const byte address[6] = "00001";
unsigned long lastReceiveTime = 0;
unsigned long currentTime = 0;

// Define the stepper motors and the pins the will use
AccelStepper LeftBackWheel(1, 42, 43); // (Type:driver, STEP, DIR) -
Stepper1
AccelStepper LeftFrontWheel(1, 40, 41); // Stepper2
AccelStepper RightBackWheel(1, 44, 45); // Stepper3
AccelStepper RightFrontWheel(1, 46, 47); // Stepper4

int wheelSpeed = 1500;

// Max size of this struct is 32 bytes - NRF24L01 buffer limit
struct Data_Package {
  byte j1PotX;
  byte j1PotY;
  byte j1Button;
  byte j2PotX;
  byte j2PotY;
  byte j2Button;
  byte pot1;
  byte pot2;
  byte tSwitch1;
  byte tSwitch2;
  byte button1;
  byte button2;
  byte button3;
  byte button4;
};
Data_Package data; //Create a variable with the above structure

void setup() {
  // Set initial seed values for the steppers
  LeftFrontWheel.setMaxSpeed(3000);
  LeftBackWheel.setMaxSpeed(3000);
  RightFrontWheel.setMaxSpeed(3000);
  RightBackWheel.setMaxSpeed(3000);

  radio.begin();
  radio.openReadingPipe(0, address);
  radio.setAutoAck(false);
  radio.setDataRate(RF24_250KBPS);
  radio.setPALevel(RF24_PA_LOW);
  radio.startListening(); // Set the module as receiver

  Serial.begin(115200);
}

void loop() {
  // Check whether we keep receving data, or we have a connection
```

between the two modules

```
    currentTime = millis();
    if ( currentTime - lastReceiveTime > 1000 ) { // If current time is
more than 1 second since we have recived the last data, that means we
have lost connection
        resetData(); // If connection is lost, reset the data. It prevents
unwanted behavior, for example if a drone jas a throttle up, if we lose
connection it can keep flying away if we dont reset the function
    }
    // Check whether there is data to be received
    if ( radio.available() ) {
        radio.read(&data, sizeof(Data_Package)); // Read the whole data and
store it into the 'data' structure
        lastReceiveTime = millis(); // At this moment we have received the
data
    }
    // Set speed - left potentiometer
    wheelSpeed = map(data.pot1, 0, 255, 100, 3000);

    if (data.j1PotX > 150) {
        moveSidewaysLeft();
    }
    else if (data.j1PotX < 100) {
        moveSidewaysRight();
    }
    else if (data.j1PotY > 160) {
        moveForward();
    }
    else if (data.j1PotY < 100) {
        moveBackward();
    }
    else if (data.j2PotX < 100 & data.j2PotY > 160) {
        moveRightForward();
    }
    else if (data.j2PotX > 160 & data.j2PotY > 160) {
        moveLeftForward();
    }
    else if (data.j2PotX < 100 & data.j2PotY < 100) {
        moveRightBackward();
    }
    else if (data.j2PotX > 160 & data.j2PotY < 100) {
        moveLeftBackward();
    }
    else if (data.j2PotX < 100) {
        rotateRight();
    }
    else if (data.j2PotX > 150) {
        rotateLeft();
    }
}
```

```
else {
    stopMoving();
}
// Execute the steps
LeftFrontWheel.runSpeed();
LeftBackWheel.runSpeed();
RightFrontWheel.runSpeed();
RightBackWheel.runSpeed();

// Monitor the battery voltage
int sensorValue = analogRead(A0);
float voltage = sensorValue * (5.0 / 1023.00) * 3; // Convert the
reading values from 5v to suitable 12V i
// If voltage is below 11V turn on the LED
if (voltage < 11) {
    digitalWrite(led, HIGH);
}
else {
    digitalWrite(led, LOW);
}
}

void moveForward() {
    LeftFrontWheel.setSpeed(wheelSpeed);
    LeftBackWheel.setSpeed(wheelSpeed);
    RightFrontWheel.setSpeed(wheelSpeed);
    RightBackWheel.setSpeed(wheelSpeed);
}

void moveBackward() {
    LeftFrontWheel.setSpeed(-wheelSpeed);
    LeftBackWheel.setSpeed(-wheelSpeed);
    RightFrontWheel.setSpeed(-wheelSpeed);
    RightBackWheel.setSpeed(-wheelSpeed);
}

void moveSidewaysRight() {
    LeftFrontWheel.setSpeed(wheelSpeed);
    LeftBackWheel.setSpeed(-wheelSpeed);
    RightFrontWheel.setSpeed(-wheelSpeed);
    RightBackWheel.setSpeed(wheelSpeed);
}

void moveSidewaysLeft() {
    LeftFrontWheel.setSpeed(-wheelSpeed);
    LeftBackWheel.setSpeed(wheelSpeed);
    RightFrontWheel.setSpeed(wheelSpeed);
    RightBackWheel.setSpeed(-wheelSpeed);
}

void rotateLeft() {
    LeftFrontWheel.setSpeed(-wheelSpeed);
    LeftBackWheel.setSpeed(-wheelSpeed);
    RightFrontWheel.setSpeed(wheelSpeed);
    RightBackWheel.setSpeed(wheelSpeed);
}
```

```
}  
void rotateRight() {  
  LeftFrontWheel.setSpeed(wheelSpeed);  
  LeftBackWheel.setSpeed(wheelSpeed);  
  RightFrontWheel.setSpeed(-wheelSpeed);  
  RightBackWheel.setSpeed(-wheelSpeed);  
}  
void moveRightForward() {  
  LeftFrontWheel.setSpeed(wheelSpeed);  
  LeftBackWheel.setSpeed(0);  
  RightFrontWheel.setSpeed(0);  
  RightBackWheel.setSpeed(wheelSpeed);  
}  
void moveRightBackward() {  
  LeftFrontWheel.setSpeed(0);  
  LeftBackWheel.setSpeed(-wheelSpeed);  
  RightFrontWheel.setSpeed(-wheelSpeed);  
  RightBackWheel.setSpeed(0);  
}  
void moveLeftForward() {  
  LeftFrontWheel.setSpeed(0);  
  LeftBackWheel.setSpeed(wheelSpeed);  
  RightFrontWheel.setSpeed(wheelSpeed);  
  RightBackWheel.setSpeed(0);  
}  
void moveLeftBackward() {  
  LeftFrontWheel.setSpeed(-wheelSpeed);  
  LeftBackWheel.setSpeed(0);  
  RightFrontWheel.setSpeed(0);  
  RightBackWheel.setSpeed(-wheelSpeed);  
}  
void stopMoving() {  
  LeftFrontWheel.setSpeed(0);  
  LeftBackWheel.setSpeed(0);  
  RightFrontWheel.setSpeed(0);  
  RightBackWheel.setSpeed(0);  
}  
  
void resetData() {  
  // Reset the values when there is no radio connection - Set initial  
  // default values  
  data.j1PotX = 127;  
  data.j1PotY = 127;  
  data.j2PotX = 127;  
  data.j2PotY = 127;  
  data.j1Button = 1;  
  data.j2Button = 1;  
  data.pot1 = 1;  
}
```

```
data.pot2 = 1;
data.tSwitch1 = 1;
data.tSwitch2 = 1;
data.button1 = 1;
data.button2 = 1;
data.button3 = 1;
data.button4 = 1;
}
```

Robot-Arduino_Mecanum000.ino

Robot-Arduino_Mecanum000.ino

```
//A tester

/*
MECANUM WHEEL ROBOT - BLUETOOTH CONTROLLED v1.0
- Allows you to control a mecanum robot via bluetooth
- Tested with Arduino Mega 2560
- Android application -
https://play.google.com/store/apps/details?id=pl.mobilerobots.vacuumcleanerrobot&hl=pl
- Project description -
http://www.instructables.com/id/Mecanum-wheel-robot-bluetooth-controlled
Author: Adam Srebro
www: http://www.mobilerobots.pl/

Connections:
Bluetooth (e.g HC-06)-> Arduino Mega 2560
TXD - TX1 (19)
RXD - RX1 (18)
VCC - 5V
GND - GND

TB6612FNG Dual Motor Driver -> Arduino Mega 2560
//PWM control
RightFrontMotor_PWMA - 2
LeftFrontMotor_PWMB - 3
RightRearMotor_PWMA - 4
LeftRearMotor_PWMB - 5
//Control of rotation direction
RightFrontMotor_AIN1 - 22
RightFrontMotor_AIN2 - 23
LeftFrontMotor_BIN1 - 24
LeftFrontMotor_BIN2 - 25
RightRearMotor_AIN1 - 26
RightRearMotor_AIN2 - 27
```

```
LeftRearMotor_BIN1 - 28
LeftRearMotor_BIN2 - 29
//The module and motors power supply
STBY - Vcc
VMOT - motor voltage (4.5 to 13.5 V) - 11.1V from LiPo battery
Vcc - logic voltage (2.7 to 5.5) - 5V from Arduino
GND - GND

TB6612FNG Dual Motor Driver -> DC Motors
MotorDriver1_A01 - RightFrontMotor
MotorDriver1_A02 - RightFrontMotor
MotorDriver1_B01 - LeftFrontMotor
MotorDriver1_B02 - LeftFrontMotor

MotorDriver2_A01 - RightRearMotor
MotorDriver2_A02 - RightRearMotor
MotorDriver2_B01 - LeftRearMotor
MotorDriver2_B02 - LeftRearMotor
*/
#include <Wire.h>
#include <math.h>
/*TB6612FNG Dual Motor Driver Carrier*/
const int RightFrontMotor_PWM = 2; // pwm output
const int LeftFrontMotor_PWM = 3; // pwm output
const int RightRearMotor_PWM = 4; // pwm output
const int LeftRearMotor_PWM = 5; // pwm output
//Front motors
const int RightFrontMotor_AIN1 = 22; // control Input AIN1 - right
front motor
const int RightFrontMotor_AIN2 = 23; // control Input AIN2 - right
front motor
const int LeftFrontMotor_BIN1 = 24; // control Input BIN1 - left front
motor
const int LeftFrontMotor_BIN2 = 25; // control Input BIN2 - left front
motor
//Rear motors
const int RightRearMotor_AIN1 = 26; // control Input AIN1 - right rear
motor
const int RightRearMotor_AIN2 = 27; // control Input AIN2 - right rear
motor
const int LeftRearMotor_BIN1 = 28; // control Input BIN1 - left rear
motor
const int LeftRearMotor_BIN2 = 29; // control Input BIN2 - left rear
motor

long pwmLvalue = 255;
long pwmRvalue = 255;
byte pwmChannel;
const char startOfNumberDelimiter = '<';
```

```
const char endOfNumberDelimiter = '>';

void setup(){
  Serial1.begin(9600); // HC-06 default baudrate: 9600

  //Setup RightFrontMotor
  pinMode(RightFrontMotor_AIN1, OUTPUT); //Initiates Motor Channel A1
  pin
  pinMode(RightFrontMotor_AIN2, OUTPUT); //Initiates Motor Channel A2
  pin

  //Setup LeftFrontMotor
  pinMode(LeftFrontMotor_BIN1, OUTPUT); //Initiates Motor Channel B1
  pin
  pinMode(LeftFrontMotor_BIN2, OUTPUT); //Initiates Motor Channel B2
  pin

  //Setup RightRearMotor
  pinMode(RightRearMotor_AIN1, OUTPUT); //Initiates Motor Channel A1
  pin
  pinMode(RightRearMotor_AIN2, OUTPUT); //Initiates Motor Channel A2
  pin

  //Setup LeftRearMotor
  pinMode(LeftRearMotor_BIN1, OUTPUT); //Initiates Motor Channel B1 pin
  pinMode(LeftRearMotor_BIN2, OUTPUT); //Initiates Motor Channel B2 pin

  Wire.begin();
} // void setup()

void loop(){
  if (Serial1.available()) {
    processInput();
  }
} // void loop()

void motorControl(String motorStr, int mdirection, int mspeed){
  int IN1;
  int IN2;
  int motorPWM;
  if (motorStr == "rf") { //right front
    IN1 = RightFrontMotor_AIN1;
    IN2 = RightFrontMotor_AIN2;
    motorPWM = RightFrontMotor_PWM;
  }
  else if (motorStr == "lf") { //left front
    IN1 = LeftFrontMotor_BIN1;
    IN2 = LeftFrontMotor_BIN2;
    motorPWM = LeftFrontMotor_PWM;
  }
  else if (motorStr == "rr") {
```

```
    IN1 = RightRearMotor_AIN1;
    IN2 = RightRearMotor_AIN2;
    motorPWM = RightRearMotor_PWM;
}
else if (motorStr == "lr") {
    IN1 = LeftRearMotor_BIN1;
    IN2 = LeftRearMotor_BIN2;
    motorPWM = LeftRearMotor_PWM;
}
if (mdirection == 1){
    digitalWrite(IN1, LOW);
    digitalWrite(IN2, HIGH);
}
else if (mdirection == -1){
    digitalWrite(IN1, HIGH);
    digitalWrite(IN2, LOW);
}
analogWrite(motorPWM, mspeed);
}

void processInput (){
    static long receivedNumber = 0;
    static boolean negative = false;
    byte c = Serial1.read ();

    switch (c){
    case endOfNumberDelimiter:
        if (negative)
            SetPWM(- receivedNumber, pwmChannel);
        else
            SetPWM(receivedNumber, pwmChannel);

        // fall through to start a new number
    case startOfNumberDelimiter:
        receivedNumber = 0;
        negative = false;
        pwmChannel = 0;
        break;

    case 'f': // Go FORWARD
        goForward(255);
        //Serial.println("forward");
        break;

    case 'b': // Go BACK
        goBackwad(255);
        //Serial.println("backward");
        break;
    }
```

```
case 'r':
  moveRight(255);
  break;

case 'l':
  moveLeft(255);
  break;

case 'i':
  turnRight(255);
  break;

case 'j':
  turnLeft(255);
  break;

case 'c': // Top Right
  moveRightForward(255);
  break;

case 'd': // Top Left
  moveLeftForward(255);
  break;

case 'e': // Bottom Right
  moveRightBackward(255);
  break;

case 'h': // Bottom Left
  moveLeftBackward(255);
  break;

case 's':
  hardStop();
  break;

case 'x':
  pwmChannel = 1; // RightFrontMotor_PWM
  break;
case 'y': // LeftFrontMotor_PWM
  pwmChannel = 2;
  break;

case '0' ... '9':
  receivedNumber *= 10;
  receivedNumber += c - '0';
  break;

case '-':
  negative = true;
  break;
```

```
    } // end of switch
} // void processInput ()

void goForward(int mspeed){
    motorControl("rf", 1, mspeed);
    motorControl("lf", 1, mspeed);
    motorControl("rr", 1, mspeed);
    motorControl("lr", 1, mspeed);
} // void goForward(int mspeed)

void goBackwad(int mspeed){
    motorControl("rf", -1, mspeed);
    motorControl("lf", -1, mspeed);
    motorControl("rr", -1, mspeed);
    motorControl("lr", -1, mspeed);
} // void goBackwad(int mspeed)

void moveRight(int mspeed){
    motorControl("rf", -1, mspeed);
    motorControl("lf", 1, mspeed);
    motorControl("rr", 1, mspeed);
    motorControl("lr", -1, mspeed);
} // void moveRight(int mspeed)

void moveLeft(int mspeed){
    motorControl("rf", 1, mspeed);
    motorControl("lf", -1, mspeed);
    motorControl("rr", -1, mspeed);
    motorControl("lr", 1, mspeed);
} // void moveLeft(int mspeed)

void moveRightForward(int mspeed){
    motorControl("rf", 1, 0);
    motorControl("lf", 1, mspeed);
    motorControl("rr", 1, mspeed);
    motorControl("lr", 1, 0);
} // void moveRightForward(int mspeed)

void moveRightBackward(int mspeed){
    motorControl("rf", -1, mspeed);
    motorControl("lf", 1, 0);
    motorControl("rr", 1, 0);
    motorControl("lr", -1, mspeed);
} // void moveRightBackward(int mspeed)

void moveLeftForward(int mspeed){
    motorControl("rf", 1, mspeed);
    motorControl("lf", 1, 0);
    motorControl("rr", 1, 0);
```

```
    motorControl("lr", 1, mspeed);
} // void moveLeftForward(int mspeed)

void moveLeftBackward(int mspeed){
    motorControl("rf", 1, 0);
    motorControl("lf", -1, mspeed);
    motorControl("rr", -1, mspeed);
    motorControl("lr", 1, 0);
} // void moveLeftBackward(int mspeed)

void turnRight(int mspeed){
    motorControl("rf", -1, mspeed);
    motorControl("lf", 1, mspeed);
    motorControl("rr", -1, mspeed);
    motorControl("lr", 1, mspeed);
} // void turnRight(int mspeed)

void turnLeft(int mspeed){
    motorControl("rf", 1, mspeed);
    motorControl("lf", -1, mspeed);
    motorControl("rr", 1, mspeed);
    motorControl("lr", -1, mspeed);
} // void turnRight(int mspeed)

void stopRobot(int delay_ms){
    analogWrite(RightFrontMotor_PWM, 0);
    analogWrite(LeftFrontMotor_PWM, 0);
    analogWrite(RightRearMotor_PWM, 0);
    analogWrite(LeftRearMotor_PWM, 0);
    delay(delay_ms);
} // void stopRobot(int delay_ms)

void hardStop(){
    analogWrite(RightFrontMotor_PWM, 0);
    analogWrite(LeftFrontMotor_PWM, 0);
    analogWrite(RightRearMotor_PWM, 0);
    analogWrite(LeftRearMotor_PWM, 0);
} // void stopRobot()

void SetPWM (const long pwm_num, byte pwm_channel){
    if(pwm_channel==1){ // DRIVE MOTOR
        analogWrite(RightFrontMotor_PWM, pwm_num);
        pwmRvalue = pwm_num;
    }
    else if(pwm_channel==2){ // STEERING MOTOR
        analogWrite(LeftFrontMotor_PWM, pwm_num);
        pwmLvalue = pwm_num;
    }
} // void SetPWM (const long pwm_num, byte pwm_channel)
```



```
#define RightMotorDirPin2B 6 //Rear Right Motor direction pin 2 to
Model-Y M_A IN2 ( K1)
#define LeftMotorDirPin1B 7 //Rear Left Motor direction pin 1 to
Model-Y M_A IN3 (K3)
#define LeftMotorDirPin2B 8 //Rear Left Motor direction pin 2 to
Model-Y M_A IN4 (K3)
#define speedPinLB 12 // Rear Wheel PWM pin connect Model-Y M_A ENB

/*motor control*/
void go_advance(int speed){
    RL_fwd(speed);
    RR_fwd(speed);
    FR_fwd(speed);
    FL_fwd(speed);
}
void go_back(int speed){
    RL_bck(speed);
    RR_bck(speed);
    FR_bck(speed);
    FL_bck(speed);
}
void right_shift(int speed_fl_fwd,int speed_rl_bck ,int
speed_rr_fwd,int speed_fr_bck) {
    FL_fwd(speed_fl_fwd);
    RL_bck(speed_rl_bck);
    RR_fwd(speed_rr_fwd);
    FR_bck(speed_fr_bck);
}
void left_shift(int speed_fl_bck,int speed_rl_fwd ,int speed_rr_bck,int
speed_fr_fwd){
    FL_bck(speed_fl_bck);
    RL_fwd(speed_rl_fwd);
    RR_bck(speed_rr_bck);
    FR_fwd(speed_fr_fwd);
}

void left_turn(int speed){
    RL_bck(0);
    RR_fwd(speed);
    FR_fwd(speed);
    FL_bck(0);
}
void right_turn(int speed){
    // RL_fwd(speed);
    // RR_bck(0);
    // FR_bck(0);
    // FL_fwd(speed);

    RL_fwd(speed);
    RR_fwd(0);
    FR_fwd(0);
}
```

```
    FL_fwd(speed);
}
void left_back(int speed){
    RL_fwd(0);
    RR_bck(speed);
    FR_bck(speed);
    FL_fwd(0);
}
void right_back(int speed){
    RL_bck(speed);
    RR_fwd(0);
    FR_fwd(0);
    FL_bck(speed);
}
void clockwise(int speed){
    RL_fwd(speed);
    RR_bck(speed);
    FR_bck(speed);
    FL_fwd(speed);
}
void countclockwise(int speed){
    RL_bck(speed);
    RR_fwd(speed);
    FR_fwd(speed);
    FL_bck(speed);
}

void FR_fwd(int speed) //front-right wheel forward turn
{
    digitalWrite(RightMotorDirPin1,HIGH);
    digitalWrite(RightMotorDirPin2,LOW);
    analogWrite(speedPinR,speed);
}
void FR_bck(int speed) // front-right wheel backward turn
{
    digitalWrite(RightMotorDirPin1,LOW);
    digitalWrite(RightMotorDirPin2,HIGH);
    analogWrite(speedPinR,speed);
}
void FL_fwd(int speed) // front-left wheel forward turn
{
    digitalWrite(LeftMotorDirPin1,HIGH);
    digitalWrite(LeftMotorDirPin2,LOW);
    analogWrite(speedPinL,speed);
}
void FL_bck(int speed) // front-left wheel backward turn
{
    digitalWrite(LeftMotorDirPin1,LOW);
```

```
digitalWrite(LeftMotorDirPin2,HIGH);
analogWrite(speedPinL,speed);
}

void RR_fwd(int speed) //rear-right wheel forward turn
{
digitalWrite(RightMotorDirPin1B, HIGH);
digitalWrite(RightMotorDirPin2B,LOW);
analogWrite(speedPinRB,speed);
}

void RR_bck(int speed) //rear-right wheel backward turn
{
digitalWrite(RightMotorDirPin1B, LOW);
digitalWrite(RightMotorDirPin2B,HIGH);
analogWrite(speedPinRB,speed);
}

void RL_fwd(int speed) //rear-left wheel forward turn
{
digitalWrite(LeftMotorDirPin1B,HIGH);
digitalWrite(LeftMotorDirPin2B,LOW);
analogWrite(speedPinLB,speed);
}

void RL_bck(int speed) //rear-left wheel backward turn
{
digitalWrite(LeftMotorDirPin1B,LOW);
digitalWrite(LeftMotorDirPin2B,HIGH);
analogWrite(speedPinLB,speed);
}

void stop_Stop() //Stop
{
analogWrite(speedPinLB,0);
analogWrite(speedPinRB,0);
analogWrite(speedPinL,0);
analogWrite(speedPinR,0);
}

//Pins initialize
void init_GPIO()
{
pinMode(RightMotorDirPin1, OUTPUT);
pinMode(RightMotorDirPin2, OUTPUT);
pinMode(speedPinL, OUTPUT);

pinMode(LeftMotorDirPin1, OUTPUT);
pinMode(LeftMotorDirPin2, OUTPUT);
pinMode(speedPinR, OUTPUT);
pinMode(RightMotorDirPin1B, OUTPUT);
pinMode(RightMotorDirPin2B, OUTPUT);
pinMode(speedPinLB, OUTPUT);
}
```

```
pinMode(LeftMotorDirPin1B, OUTPUT);
pinMode(LeftMotorDirPin2B, OUTPUT);
pinMode(speedPinRB, OUTPUT);

stop_Stop();
}

void setup()
{
  init_GPIO();

  go_advance(SPEED);
  delay(1000);
  stop_Stop();
  delay(1000);

  go_back(SPEED);
  delay(1000);
  stop_Stop();
  delay(1000);

  left_turn(TURN_SPEED);
  delay(1000);
  stop_Stop();
  delay(1000);

  right_turn(TURN_SPEED);
  delay(1000);
  stop_Stop();
  delay(1000);

  right_shift(200,200,200,200); //right shift
  delay(1000);
  stop_Stop();
  delay(1000);

  left_shift(200,200,200,200); //left shift
  delay(1000);
  stop_Stop();
  delay(1000);

  left_shift(200,0,200,0); //left diagonal back
  delay(1000);
  stop_Stop();
  delay(1000);

  right_shift(200,0,200,0); //right diagonal ahead
  delay(1000);
```

```

    stop_Stop();
    delay(1000);

left_shift(0,200,0,200); //left diagonal ahead
    delay(1000);
    stop_Stop();
    delay(1000);

right_shift(0,200,0,200); //right diagonal back
    delay(1000);
    stop_Stop();
    delay(1000);
}

void loop(){
}

```

Robot-Arduino_Mecanum_002.ino

Robot-Arduino_Mecanum_001.ino

```

/*
 * /_ \ /_ )/_ \| | | |/_ \ /_ \ /_ )_ \| | | |
 * | | | | | | | | | | | | | | ( ( | | | | | |
 * \_ / ( \ / \_ / \_ \| | | | \_ / \_ ( ) \_ )_ \| | | |
 *
 * ( \_ /
 * Omni direction Mecanum Wheel Arduino Smart Car Tutorial Lesson 2
 * Obstacle avoidance auto driving.
 * Tutorial URL https://osoyoo.com/?p=43404
 * Copyright www.osoyoo.com
 *
 * This project will show you how to make osoyoo robot car in auto
 * drive mode and avoid obstacles
 *
 *
 */
#include <Servo.h>
#define speedPinR 9 // Front Wheel PWM pin connect Model-Y M_B ENA
#define RightMotorDirPin1 22 //Front Right Motor direction pin 1 to
Model-Y M_B IN1 (K1)
#define RightMotorDirPin2 24 //Front Right Motor direction pin 2 to
Model-Y M_B IN2 (K1)
#define LeftMotorDirPin1 26 //Front Left Motor direction pin 1 to
Model-Y M_B IN3 (K3)
#define LeftMotorDirPin2 28 //Front Left Motor direction pin 2 to
Model-Y M_B IN4 (K3)
#define speedPinL 10 // Front Wheel PWM pin connect Model-Y M_B ENB

```

```
#define speedPinRB 11 // Rear Wheel PWM pin connect Left Model-Y M_A ENA
#define RightMotorDirPin1B 5 //Rear Right Motor direction pin 1 to Model-Y M_A IN1 ( K1)
#define RightMotorDirPin2B 6 //Rear Right Motor direction pin 2 to Model-Y M_A IN2 ( K1)
#define LeftMotorDirPin1B 7 //Rear Left Motor direction pin 1 to Model-Y M_A IN3 (K3)
#define LeftMotorDirPin2B 8 //Rear Left Motor direction pin 2 to Model-Y M_A IN4 (K3)
#define speedPinLB 12 // Rear Wheel PWM pin connect Model-Y M_A ENB

#define LPT 2 // scan loop counter

#define SERVO_PIN 13 //servo connect to D5

#define Echo_PIN 31 // Ultrasonic Echo pin connect to A5
#define Trig_PIN 30 // Ultrasonic Trig pin connect to A4

#define FAST_SPEED 160 //both sides of the motor speed
#define SPEED 120 //both sides of the motor speed
#define TURN_SPEED 120 //both sides of the motor speed
#define BACK_SPEED1 160 //back speed
#define BACK_SPEED2 90 //back speed

int leftscanval, centerscanval, rightscanval, ldiagonalscanval, rdiagonalscanval;
const int distancelimit = 30; //distance limit for obstacles in front
const int sidedistancelimit = 30; //minimum distance in cm to obstacles at both sides (the car will allow a shorter distance sideways)
int distance;
int numcycles = 0;
const int turntime = 250; //Time the robot spends turning (miliseconds)
const int backtime = 300; //Time the robot spends turning (miliseconds)

int thereis;
Servo head;
/*motor control*/
void go_Advance() //Forward
{
FR_fwd();
FL_fwd();
RR_fwd();
RL_fwd();
}
void go_Left() //Turn left
{
FR_fwd();
FL_bck();
```

```
RR_fwd();
RL_bck();
}
void go_Right() //Turn right
{
FR_bck();
FL_fwd();
RR_bck();
RL_fwd();
}
void go_Back() //Reverse
{
FR_bck();
FL_bck();
RR_bck();
RL_bck();
}

void stop_Stop() //Stop
{
digitalWrite(RightMotorDirPin1, LOW);
digitalWrite(RightMotorDirPin2, LOW);
digitalWrite(LeftMotorDirPin1, LOW);
digitalWrite(LeftMotorDirPin2, LOW);
digitalWrite(RightMotorDirPin1B, LOW);
digitalWrite(RightMotorDirPin2B, LOW);
digitalWrite(LeftMotorDirPin1B, LOW);
digitalWrite(LeftMotorDirPin2B, LOW);
set_Motorspeed(0,0,0,0);
}

/*set motor speed */
void set_Motorspeed(int leftFront,int rightFront,int leftBack,int
rightBack)
{
analogWrite(speedPinL, leftFront);
analogWrite(speedPinR, rightFront);
analogWrite(speedPinLB, leftBack);
analogWrite(speedPinRB, rightBack);
}

void FR_fwd() //front-right wheel forward turn
{
digitalWrite(RightMotorDirPin1, HIGH);
digitalWrite(RightMotorDirPin2, LOW);
}
void FR_bck() // front-right wheel backward turn
{
```

```
digitalWrite(RightMotorDirPin1,LOW);
digitalWrite(RightMotorDirPin2,HIGH);
}
void FL_fwd() // front-left wheel forward turn
{
digitalWrite(LeftMotorDirPin1,HIGH);
digitalWrite(LeftMotorDirPin2,LOW);
}
void FL_bck() // front-left wheel backward turn
{
digitalWrite(LeftMotorDirPin1,LOW);
digitalWrite(LeftMotorDirPin2,HIGH);
}

void RR_fwd() //rear-right wheel forward turn
{
digitalWrite(RightMotorDirPin1B,HIGH);
digitalWrite(RightMotorDirPin2B,LOW);
}
void RR_bck() //rear-right wheel backward turn
{
digitalWrite(RightMotorDirPin1B,LOW);
digitalWrite(RightMotorDirPin2B,HIGH);
}

void RL_fwd() //rear-left wheel forward turn
{
digitalWrite(LeftMotorDirPin1B,HIGH);
digitalWrite(LeftMotorDirPin2B,LOW);
}
void RL_bck() //rear-left wheel backward turn
{
digitalWrite(LeftMotorDirPin1B,LOW);
digitalWrite(LeftMotorDirPin2B,HIGH);
}

/*detection of ultrasonic distance*/
int watch(){
long echo_distance;
digitalWrite(Trig_PIN,LOW);
delayMicroseconds(5);
digitalWrite(Trig_PIN,HIGH);
delayMicroseconds(15);
digitalWrite(Trig_PIN,LOW);
echo_distance=pulseIn(Echo_PIN,HIGH);
echo_distance=echo_distance*0.01657; //how far away is the object in
cm
//Serial.println((int)echo_distance);
```

```

    return round(echo_distance);
}
//Measures distances to the right, left, front, left diagonal, right
diagonal and assign them in cm to the variables rightscanval,
//leftscanval, centerscanval, ldiagonalscanval and rdiagonalscanval
//there are 5 points for distance testing)
String watchsurrounding(){
/* obstacle_status is a binary integer, its last 5 digits stands for
if there is any obstacles in 5 directions,
* for example B101000 last 5 digits is 01000, which stands for Left
front has obstacle, B100111 means front, right front and right ha
*/

int obstacle_status =B100000;
centerscanval = watch();
if(centerscanval<distancelimit){
    stop_Stop();

    obstacle_status =obstacle_status | B100;
}
head.write(120);
delay(100);
ldiagonalscanval = watch();
if(ldiagonalscanval<distancelimit){
    stop_Stop();

    obstacle_status =obstacle_status | B1000;
}
head.write(170); //Didn't use 180 degrees because my servo is not
able to take this angle
delay(300);
leftscanval = watch();
if(leftscanval<sidedistancelimit){
    stop_Stop();

    obstacle_status =obstacle_status | B10000;
}

head.write(90); //use 90 degrees if you are moving your servo through
the whole 180 degrees
delay(100);
centerscanval = watch();
if(centerscanval<distancelimit){
    stop_Stop();

    obstacle_status =obstacle_status | B100;
}
head.write(40);
delay(100);
rdiagonalscanval = watch();
if(rdiagonalscanval<distancelimit){

```

```
stop_Stop();

obstacle_status =obstacle_status | B10;
}
head.write(0);
delay(100);
rightscanval = watch();
if(rightscanval<sidedistancelimit){
stop_Stop();

obstacle_status =obstacle_status | 1;
}
head.write(90); //Finish looking around (look forward again)
delay(300);
String obstacle_str= String(obstacle_status,BIN);
obstacle_str= obstacle_str.substring(1,6);

return obstacle_str; //return 5-character string standing for 5
direction obstacle status
}

void auto_avoidance(){

++numcycles;
if(numcycles>=LPT){ //Watch if something is around every LPT loops
while moving forward
stop_Stop();
String obstacle_sign=watchsurrounding(); // 5 digits of
obstacle_sign binary value means the 5 direction obstacle status
Serial.print("begin str=");
Serial.println(obstacle_sign);
if( obstacle_sign=="10000"){
Serial.println("SLIT right");
set_Motorspeed(FAST_SPEED,SPEED,FAST_SPEED,SPEED);
go_Advance();

delay(turntime);
stop_Stop();
}
else if( obstacle_sign=="00001" ){
Serial.println("SLIT LEFT");
set_Motorspeed(SPEED,FAST_SPEED,SPEED,FAST_SPEED);
go_Advance();

delay(turntime);
stop_Stop();
}
else if( obstacle_sign=="11100" || obstacle_sign=="01000" ||
obstacle_sign=="11000" || obstacle_sign=="10100" ||
```

```

obstacle_sign=="01100" || obstacle_sign=="00100"
|| obstacle_sign=="01000" ){
    Serial.println("hand right");
    go_Right();
    set_Motorspeed(TURN_SPEED,TURN_SPEED,TURN_SPEED,TURN_SPEED);
    delay(turntime);
    stop_Stop();
}
else if( obstacle_sign=="00010" || obstacle_sign=="00111" ||
obstacle_sign=="00011" || obstacle_sign=="00101" ||
obstacle_sign=="00110" || obstacle_sign=="01010" ){
    Serial.println("hand left");
    go_Left();//Turn left
    set_Motorspeed(TURN_SPEED,TURN_SPEED,TURN_SPEED,TURN_SPEED);
    delay(turntime);
    stop_Stop();
}

else if( obstacle_sign=="01111" || obstacle_sign=="10111" ||
obstacle_sign=="11111" ){
    Serial.println("hand back left");
    go_Back();
    set_Motorspeed(
BACK_SPEED1,BACK_SPEED2,BACK_SPEED1,BACK_SPEED2);
    delay(backtime);
    stop_Stop();
}
else if( obstacle_sign=="11011" || obstacle_sign=="11101"
|| obstacle_sign=="11110" || obstacle_sign=="01110" ){
    Serial.println("hand back right");
    go_Back();
    set_Motorspeed(BACK_SPEED2,BACK_SPEED1,BACK_SPEED2,BACK_SPEED1);
    delay(backtime);
    stop_Stop();
}

else Serial.println("no handle");
numcycles=0; //Restart count of cycles
} else {
    set_Motorspeed(SPEED,SPEED,SPEED,SPEED);
    go_Advance(); // if nothing is wrong go forward using go()
function above.
    delay(backtime);
    stop_Stop();
}

//else Serial.println(numcycles);

distance = watch(); // use the watch() function to see if anything is
ahead (when the robot is just moving forward and not looking around it
will test the distance in front)

```

```
    if (distance<distancelimit){ // The robot will just stop if it is
    completely sure there's an obstacle ahead (must test 25 times) (needed
    to ignore ultrasonic sensor's false signals)
    Serial.println("final go back");
    go_Back();
    set_Motorspeed(BACK_SPEED1,BACK_SPEED2,BACK_SPEED1,BACK_SPEED2);
    delay(backtime);
    ++thereis;}
    if (distance>distancelimit){
    thereis=0;} //Count is restarted
    if (thereis > 25){
    Serial.println("final stop");
    stop_Stop(); // Since something is ahead, stop moving.
    thereis=0;
    }
}

void setup() {
    /*setup L298N pin mode*/
    pinMode(RightMotorDirPin1, OUTPUT);
    pinMode(RightMotorDirPin2, OUTPUT);
    pinMode(speedPinL, OUTPUT);

    pinMode(LeftMotorDirPin1, OUTPUT);
    pinMode(LeftMotorDirPin2, OUTPUT);
    pinMode(speedPinR, OUTPUT);
    pinMode(RightMotorDirPin1B, OUTPUT);
    pinMode(RightMotorDirPin2B, OUTPUT);
    pinMode(speedPinLB, OUTPUT);

    pinMode(LeftMotorDirPin1B, OUTPUT);
    pinMode(LeftMotorDirPin2B, OUTPUT);
    pinMode(speedPinRB, OUTPUT);
    stop_Stop();//stop move
    /*init HC-SR04*/
    pinMode(Trig_PIN, OUTPUT);
    pinMode(Echo_PIN,INPUT);
    /*init buzzer*/

    digitalWrite(Trig_PIN,LOW);
    /*init servo*/
    head.attach(SERVO_PIN);
    head.write(0);
    delay(1000);
    head.write(170);
    delay(1000);
    head.write(90);
    delay(8000);
```

```
Serial.begin(9600);

stop_Stop();//Stop

}

void loop() {
  auto_avoidance();
  // Serial.println( watchsurrounding());
}
```

Achat robot Mecanum



[Achat Aliexpress ~ 50€](#)

[Achat RobotShop ~420€..](#)

[Achat KUBII ~ 130€](#)

Liens Projets Arduino Robot Mecanum

[Projet 1 Robot Mecanum EN](#)

[Projet 2 Robot Mecanum EN](#)

[Projet 3 Robot Mecanum EN](#)

Programme Robot Mecanum

Robot Mecanum 001

[robot_Original_Mecanum.ino](#)

```
// Tester par GL Fontionne mais ne permet pas tout les Mouvements
//2020.11.22
//Configure THE PWM control pin
const int PWM2A = 11; //M1 motor
const int PWM2B = 3; //M2 motor
const int PWM0A = 6; //M3 motor
const int PWM0B = 5; //M4 motor

const int DIR_CLK = 4; // Data input clock line
const int DIR_EN = 7; //Equip the L293D enabling pins
const int DATA = 8; // USB cable
const int DIR_LATCH = 12; // Output memory latch clock
//Define the pin of ultrasonic obstacle avoidance sensor
const int Trig = A2; //A2 is defined as the pin Trig connected to
the ultrasonic sensor
const int Echo = A3; //A3 is defined as the pin Echo connected to
the ultrasonic sensor
//Define motion state
const int Forward = 39; //39存放到Forward
const int Back = 216; //216存放到Back
const int Left = 57; //57存放到Left变量中
const int Right = 198; //The right amount of change
const int Stop = 0; //Parking variable
//Set the default speed between 1 and 255
int Speed1 = 180; //PWM0B -M3
int Speed2 = 180; //PWM0A -M4
int Speed3 = 180; //PWM2A -M3
int Speed4 = 180; //PWM2B -M4

int distance = 0; //Variables for storing ultrasonic sensor
measurements
char serialData; //把串口接收的数据存放serialData中
char cmd; //Store bluetooth receive commands

void setup()
{
    Serial.begin(9600); //Set the serial port baud rate 9600
```

```

    //Configure as output mode
    pinMode(DIR_CLK,OUTPUT);
    pinMode(DATA,OUTPUT);
    pinMode(DIR_EN,OUTPUT);
    pinMode(DIR_LATCH,OUTPUT);
    pinMode(PWM0B,OUTPUT);
    pinMode(PWM0A,OUTPUT);
    pinMode(PWM2A,OUTPUT);
    pinMode(PWM2B,OUTPUT);

    pinMode(Trig,OUTPUT);//The Trig pin connected to the ultrasound is
set to output mode
    pinMode(Echo,INPUT);//The Echo pin connected to the ultrasound is
set to input mode

    void Motor(int Dri,int Speed1,int Speed2,int Speed3,int Speed4);
    int SR04(int Trig,int Echo);
    void AvoidingObstacles();
    void HC05();
}

void loop()
{
    distance = SR04(Trig,Echo);    //Acquisition of ultrasonic
distance

    HC05(); //Call the Bluetooth car control function
}

/* Function name: Motor();
* Function: Change the movement direction and speed of the car through
the entrance parameters
* Entry parameter 1: Dri car movement direction
* Entry parameters 2~3: Speed1~Speed4 motor speed, value range 0~255
* Dri value description (forward :39; Back: 216; Left translation: 57;
Right translation: 198; Stop: 0;
* Right rotation: 106; Left rotation: 149)
* Return value: None
*/
void Motor(int Dir,int Speed1,int Speed2,int Speed3,int Speed4)
{
    analogWrite(PWM2A,Speed1); //Motor PWM speed regulation
    analogWrite(PWM2B,Speed2); //Motor PWM speed regulation
    analogWrite(PWM0A,Speed3); //Motor PWM speed regulation
    analogWrite(PWM0B,Speed4); //Motor PWM speed regulation

    digitalWrite(DIR_LATCH,LOW); //DIR_LATCH sets the low level and
writes the direction of motion in preparation

```

```
    shiftOut(DATA,DIR_CLK,MSBFIRST,Dir);//Write Dir motion direction
    value

    digitalWrite(DIR_LATCH,HIGH);//DIR_LATCH sets the high level and
    outputs the direction of motion
}

/*
Function name: SR04()
Function: Obtain ultrasonic ranging data
Entry parameters: Trig, Echo
Function return value: cm
*/
int SR04(int Trig,int Echo)
{
    float cm = 0;

    digitalWrite(Trig,LOW);    //Trig is set to low level
    delayMicroseconds(2);    //Wait 2 microseconds
    digitalWrite(Trig,HIGH);    //Trig is set to high level
    delayMicroseconds(15);    //Wait 15 microseconds
    digitalWrite(Trig,LOW);    //Trig is set to low

    cm = pulseIn(Echo,HIGH)/58.8; //Convert the ranging time to CM
    cm = (int(cm * 100.0))/100.0; //Leave 2 as a decimal
    Serial.print("Distance:");    //Character Distance displayed in
    serial port monitor window:
    Serial.print(cm);
    Serial.println("cm");

    return cm;    //Returns cm value ranging data
}

/*
* Function name: HC05()
* Function: Receive Bluetooth data, control the car movement direction
* Entry parameters: None
* Return value: None
*/
void HC05()
{
    if(Serial.available() > 0)    //Determine if the received data is
    greater than 0
    {
        serialData = Serial.read(); //Receiving function

        if ('F' == serialData ) cmd = 'F';    //If the data
        received by the serial port is character F, save F to CMD
        else if('B' == serialData ) cmd = 'B';    //If the data
        received by the serial port is character B, save F to CMD
    }
}
```

```

    else if('L' == serialData ) cmd = 'L';    //If the serial
port receives data as the character L, save F to CMD
    else if('R' == serialData ) cmd = 'R';    //If the serial
port receives data as the character R, save F to CMD
    else if('S' == serialData ) cmd = 'S';    //If the serial
port receives data as character S, save F to CMD

    else if( serialData == '+' && Speed1 < 245)//If you receive a
string plus, the speed increases
    {
        Speed1 += 10;    //We're going to increase the velocity by
10 at a time
        Speed2 = Speed1;
        Speed3 = Speed1;
        Speed4 = Speed1;
    }
    else if( serialData == '-' && Speed1 > 30)//When I receive a
string -- the speed decreases
    {
        Speed1 -= 10;    //I'm going to subtract 10 at a time
        Speed2 = Speed1;
        Speed3 = Speed1;
        Speed4 = Speed1;
    }

    else if('A' == serialData) //Bluetooth received the string R,
car right translation
    {
        Motor(106,Speed1,Speed2,Speed3,Speed4);    //
        delay(100);
    }
    else if('C' == serialData) //Bluetooth received the string R,
car right translation
    {
        Motor(149,Speed1,Speed2,Speed3,Speed4);    //
        delay(100);
    }
}

if('F' == cmd)    //If Bluetooth receives the string F, the dolly
moves forward and enables obstacle avoidance
{
    AvoidingObstacles();//The ultrasonic obstacle avoidance function
is called to realize the obstacle avoidance function
}
else if('B' == cmd)    //Bluetooth receives string B, car backs up
{
    Motor(Back,Speed1,Speed2,Speed3,Speed4);
}
else if('L' == cmd)    //Bluetooth received the string L, car left
translation

```

```
{
    Motor(Left,Speed1,Speed2,Speed3,Speed4);
}
else if('R' == cmd) //Bluetooth received the string R, car
right translation
{
    Motor(Right,Speed1,Speed2,Speed3,Speed4); //right
translation
}

else if('S' == serialData) //When the string S is received,
the cart stops moving
{
    Motor(Stop,0,0,0,0);
}
}

void AvoidingObstacles()
{
    if((distance > 20 ) || cmd == 'F')//If the distance is greater than
20cm or bluetooth receives a command equal to F
    {
        delay(100);//Delay of 100 ms
        if(distance > 20)//Again, determine if the distance is really
greater than 20cm
        {
            Motor(Forward,Speed1,Speed2,Speed3,Speed4); //Call forward
function
        }
        else //Otherwise the distance is less than 20
        {
            Motor(Back,Speed1,Speed2,Speed3,Speed4);//retreat
            delay(500);
            Motor(106,Speed1,Speed2,Speed3,Speed4);//Turn left to
change the direction of the car
            delay(500);
        }
    }
}
}
```

Robot Mecanum Version 2 modifié par GL

[Robot_Mecanum002.ino](#)

```
// Tester par GL le 31 juillet 2022
//Avec compensation vitesse moteur gauche ( M1 et M2 )
```

```
#include <MotorDriver.h>

//Define the pin of ultrasonic obstacle avoidance sensor
const int Trig = A2;      //A2 is defined as the pin Trig connected to
the ultrasonic sensor
const int Echo = A3;      //A3 is defined as the pin Echo connected to
the ultrasonic sensor

MotorDriver m;

int vit=180;
int comp = ( vit / 3); // compensation de 1/3 de la vitesse pour les
moteurs gauche par rapport aux moteurs droit
int vitcomp= (vit - comp);
;
int tempo = 1000;
int dure= 2;

int distance = 0;        //Variables for storing ultrasonic sensor
measurements
char serialData;
char cmd;

void arret()
{
  m.motor(1,RELEASE,0);
  m.motor(2,RELEASE,0);
  m.motor(3,RELEASE,0);
  m.motor(4,RELEASE,0);
}

void avant()
{
  m.motor(1,FORWARD,vitcomp);
  m.motor(2,FORWARD,vitcomp);
  m.motor(3,FORWARD,vit);
  m.motor(4,FORWARD,vit);
}

void arriere()
{
  m.motor(1,BACKWARD,vitcomp);
  m.motor(2,BACKWARD,vitcomp);
  m.motor(3,BACKWARD,vit);
  m.motor(4,BACKWARD,vit);
}

void LatDroite()
{
```

```
m.motor(1, FORWARD, vitcomp);
m.motor(2, BACKWARD, vitcomp);
m.motor(3, FORWARD, vit);
m.motor(4, BACKWARD, vit);
}

void LatGauche()
{
  m.motor(1, BACKWARD, vitcomp);
  m.motor(2, FORWARD, vitcomp);
  m.motor(3, BACKWARD, vit);
  m.motor(4, FORWARD, vit);
}

void BiaisDroite()
{
  m.motor(1, FORWARD, vitcomp);
  m.motor(2, RELEASE, 0);
  m.motor(3, FORWARD, vit);
  m.motor(4, RELEASE, 0);
}

void BiaisGauche()
{
  m.motor(1, RELEASE, 0);
  m.motor(2, FORWARD, vitcomp);
  m.motor(3, RELEASE, 0);
  m.motor(4, FORWARD, vit);
}

void TourneDroite()
{
  m.motor(1, FORWARD, vitcomp);
  m.motor(2, FORWARD, vitcomp);
  m.motor(3, RELEASE, 0);
  m.motor(4, RELEASE, 0);
}

void TourneGauche()
{
  m.motor(1, RELEASE, 0);
  m.motor(2, RELEASE, 0);
  m.motor(3, FORWARD, vit);
  m.motor(4, FORWARD, vit);
}

void DemiTourDroite()
```

```
{
  m.motor(1, FORWARD, vitcomp);
  m.motor(2, FORWARD, vitcomp);
  m.motor(3, BACKWARD, vit);
  m.motor(4, BACKWARD, vit);
}

void DemiTourGauche()
{
  m.motor(1, BACKWARD, vitcomp);
  m.motor(2, BACKWARD, vitcomp);
  m.motor(3, FORWARD, vit);
  m.motor(4, FORWARD, vit);
}

int SR04(int Trig, int Echo)
{
  float cm = 0;

  digitalWrite(Trig, LOW); //Trig is set to low level
  delayMicroseconds(2); //Wait 2 microseconds
  digitalWrite(Trig, HIGH); //Trig is set to high level
  delayMicroseconds(15); //Wait 15 microseconds
  digitalWrite(Trig, LOW); //Trig is set to low

  cm = pulseIn(Echo, HIGH)/58.8; //Convert the ranging time to CM
  cm = (int(cm * 100.0))/100.0; //Leave 2 as a decimal
  //Serial.print("Distance:"); //Character Distance displayed in
  serial port monitor window:
  //Serial.print(cm);
  //Serial.println("cm");

  return cm; //Returns cm value ranging data
}

void AvoidingObstacles()
{
  if((distance > 20 ) || cmd == 'F')//If the distance is greater than
  20cm or bluetooth receives a command equal to F
  {
    delay(100); //Delay of 100 ms
    if(distance > 20)//Again, determine if the distance is really
    greater than 20cm
    {
      avant();
    }
    else //Otherwise the distance is less than 20
    {
      arriere();
      delay(500);
      TourneGauche();
    }
  }
}
```

```
        delay(500);
    }
}

void HC05()
{
    if(Serial.available() > 0) //Determine if the received data is
greater than 0
    {
        serialData = Serial.read(); //Receiving function
        Serial.print("Serial Data: ");
        Serial.println(serialData);

        if ('F' == serialData ) cmd = 'F'; //Avant
        else if('B' == serialData ) cmd = 'B'; //Arriere
        else if('L' == serialData ) cmd = 'L'; //Tourne Gauche
        else if('R' == serialData ) cmd = 'R'; //Tourne Droite
        else if('S' == serialData ) cmd = 'S'; //Stop
        else if('A' == serialData ) cmd = 'A'; //Lateral Droite
        else if('C' == serialData ) cmd = 'C'; //Lateral Gauche
        else if('D' == serialData ) cmd = 'D'; //Demi Tour

        else if( serialData == '+' && vit < 245)//If you receive a
string plus, the speed increases
        {
            comp += 5; //We're going to increase the velocity by 10
at a time

        }
        else if( serialData == '-' && vit > 30)//When I receive a
string -- the speed decreases
        {
            comp -= 5; //I'm going to subtract 10 at a time
        }
        Serial.print("Vitesse = ");
        Serial.println(vit);
        Serial.print("Vitesse comp = ");
        Serial.println(vitcomp);
    }

    if('F' == cmd) //If Bluetooth receives the string F, the dolly
moves forward and enables obstacle avoidance
    {
        avant();
        //AvoidingObstacles();//The ultrasonic obstacle avoidance
function is called to realize the obstacle avoidance function
    }
}
```

```
    }
    else if('B' == cmd) //Bluetooth receives string B, car backs up
    {
        arriere();
    }
    else if('L' == cmd) //Bluetooth received the string L, car left
translation
    {
        TourneGauche();
    }
    else if('R' == cmd) //Bluetooth received the string R, car
right translation
    {
        TourneDroite(); //right translation
    }

    else if('S' == serialData) //When the string S is received,
the cart stops moving
    {
        arret();
    }
    else if('A' == serialData)
    {
        LatDroite();
    }
    else if('C' == serialData)
    {
        LatGauche();
    }
    else if('D' == serialData)
    {
        DemiTourDroite();
    }
}

void setup()
{
    Serial.begin(9600);

    pinMode(Trig,OUTPUT);//The Trig pin connected to the ultrasound is set
to output mode
    pinMode(Echo,INPUT);//The Echo pin connected to the ultrasound is set
to input mode

    void Motor(int Dri,int Speed1,int Speed2,int Speed3,int Speed4);
    int SR04(int Trig,int Echo);
    void AvoidingObstacles();
    void HC05();
}
```

```
void loop()  
{  
  distance = SR04(Trig,Echo); //Acquisition of ultrasonic  
  distance  
  
  HC05(); //Call the Bluetooth car control function  
}
```

Cablage Robot Mecanum

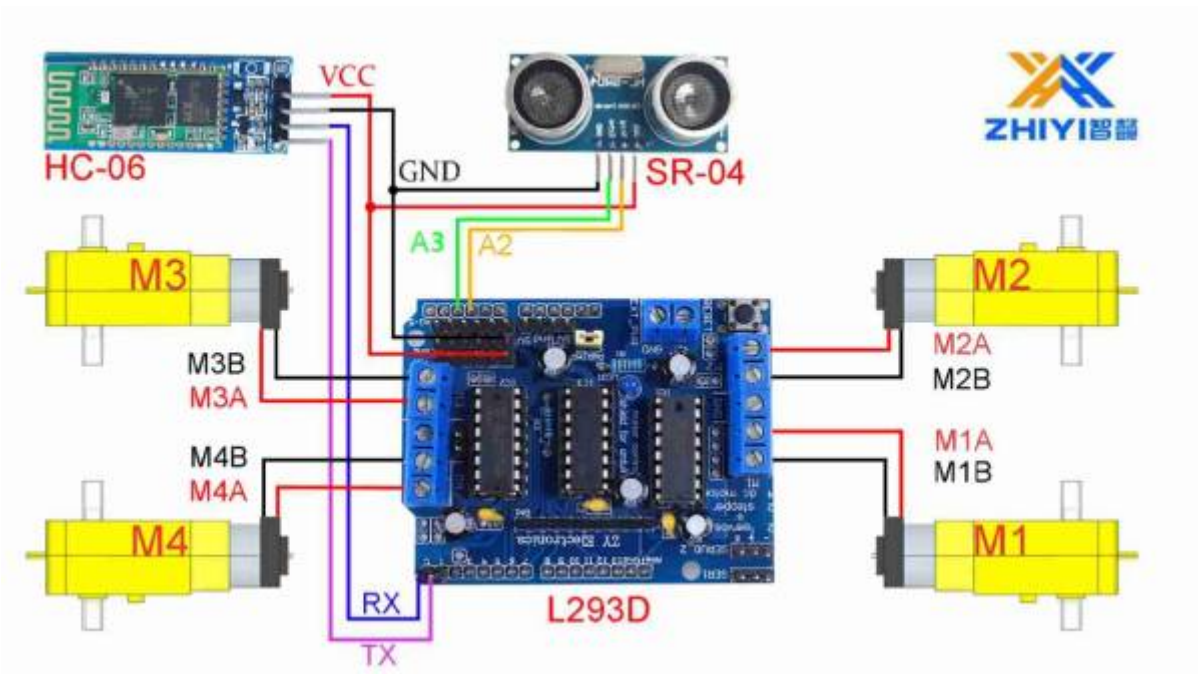

Cablage SR04

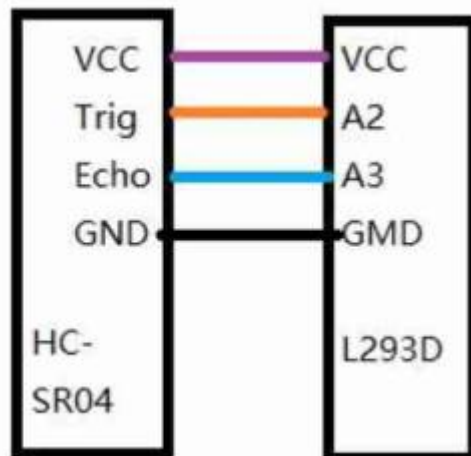
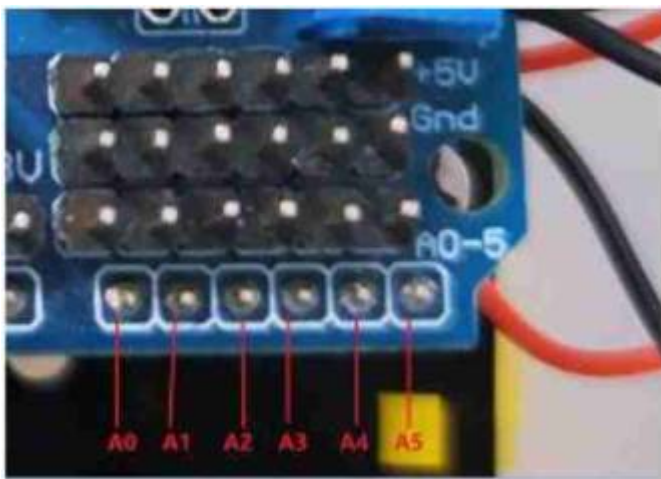
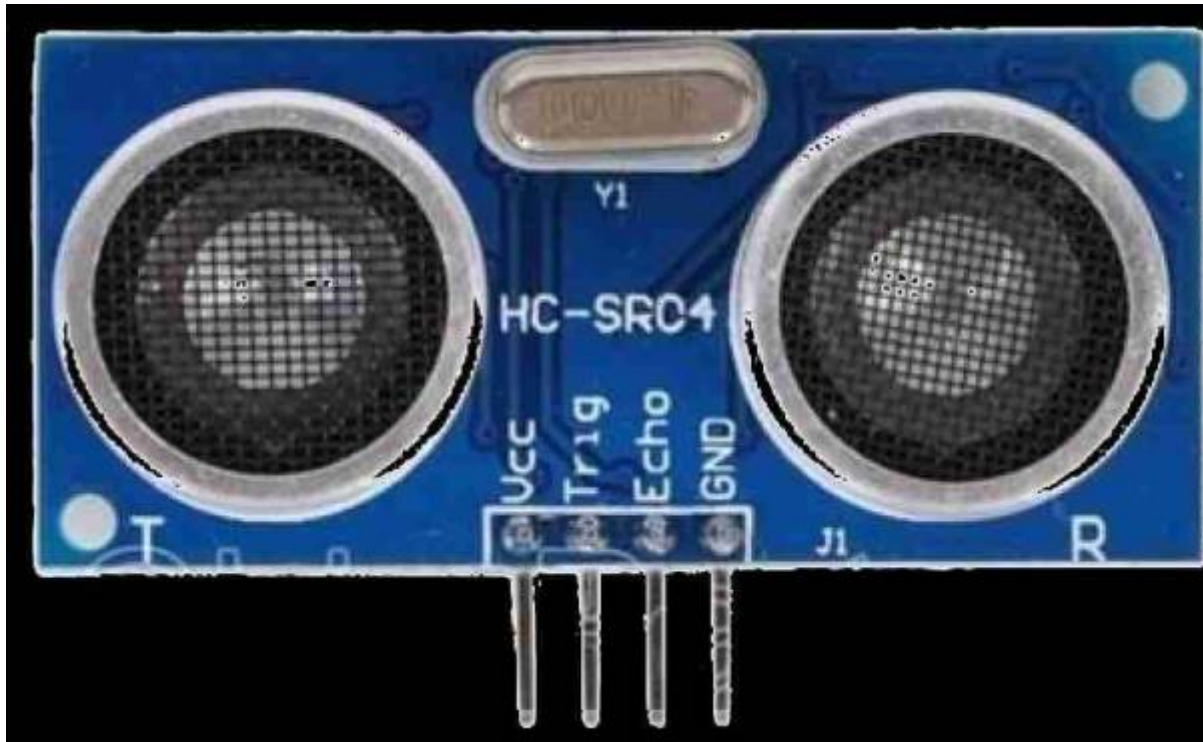

From: <https://www.fablab37110.chanterie37.fr/> - Castel'Lab le Fablab MJC de Château-Renault

Permanent link: <https://www.fablab37110.chanterie37.fr/doku.php?id=start:arduino:robots:mecanum&rev=1659261062>

Last update: 2023/01/27 16:08

