

NRF24L01

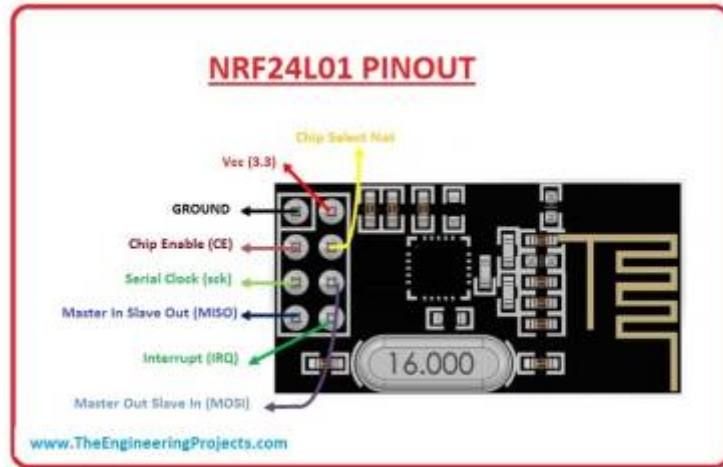

Faire dialoguer un Raspberry et un Arduino via nRF24L01

[Arduino et Raspberry : le Dialogue](#)

Datasheet NRF24L01

nrf24l01_prelim_prod_spec_1_2.pdf

[Explications Librairie NF24 EN](#)

Utilisation du module nRF24L01+ avec l'Arduino

[NRF24L01 et Arduino -1-](#)

[NRF24L01 et Arduino -2-](#)

[NRF24L01 et Arduino -3-](#)

[NRF24L01 et Arduino -4-](#)

[Acquitement NRF24L01](#)

[Probleme courant NRF24L01](#)

[C++ \(Cpp\) RF24::setAutoAck Exemples](#)

Utilisation du module nRF24L01+ avec un ESP32

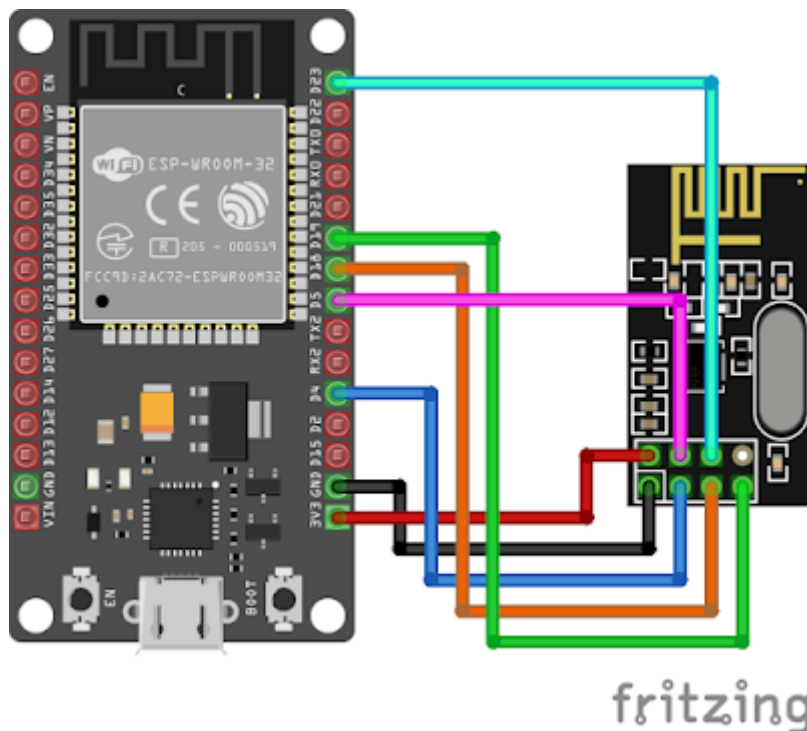

Branchement du module nRF24L01 à la carte ESP32 :

- GND du nRF24L01 - GND de l'ESP32
- VCC du nRF24L01 - 3V3 de l'ESP32
- CE du nRF24L01 - D4 de l'ESP32
- CSN du nRF24L01 - D5 de l'ESP32
- SCK du nRF24L01 - D18 de l'ESP32
- MOSI du nRF24L01 - D23 de l'ESP32
- MISO du nRF24L01 - D19 de l'ESP32
- IRQ du nRF24L01 - Pas branché

Programmes Exemple

Esp32_NRF24L01_Emission_001.ino

```
/*
*****
Chaque seconde, un nombre est émis par un module nRF24L01
branché à une carte ESP32 ou ESP8266.
*****
*/

#include <SPI.h>
#include "nRF24L01.h"
#include "RF24.h"

int compteur = 0;

RF24 radio(4, 5);
const uint64_t adresse = 0x1111111111;
const int taille = 32;
char message[taille + 1];

void setup(void)
{
  Serial.begin(115200);
  Serial.println("Emetteur de donnees");
  radio.begin();
  radio.openWritingPipe(adresse);
}

void loop(void)
{
  compteur++;
  itoa(compteur, message, 10);
  Serial.print("J'envoie maintenant "); // pour débogage
  Serial.println(message);

  radio.write( message, taille ); // émission du message via nRF24L01

  delay(1000);
}
```

Esp32_NRF24L01_Reception001.ino

```
/*
*****

Sketch permettant à un ESP32 ou un ESP8266 de recevoir des messages
en provenance d'un autre microcontrôleur par l'entremise d'un
module nRF24L01.
*****
*/
```

Les messages reçus sont affichés dans le moniteur série.

```
*****/

#include <SPI.h>
#include "nRF24L01.h"
#include "RF24.h"

RF24 radio(4, 5);

const uint64_t adresse = 0x1111111111;
const int taille = 32;
char message[taille + 1];

void setup(void)
{
  Serial.begin(115200);
  Serial.println("Recepteur RF24");
  radio.begin();
  radio.openReadingPipe(1, adresse);
  radio.startListening();
}

void loop(void)
{
  while ( radio.available() )
  {
    radio.read( message, taille );
    Serial.print("Message recu : ");
    Serial.println(message);
  }
}
```

Maquette de test

[ESP32_BP_NRF24L01_Emission002_GL.ino](#)

```
#include <DFRobot_MCP23017.h>

#include <SPI.h>
#include "nRF24L01.h"
#include "RF24.h"

//definition tunnel communication
#define tunnel1 "PIPE1"
#define tunnel2 "PIPE2"
#define tunnel3 "PIPE3"
```

```

#define tunnel4 "PIPE4"
#define tunnel5 "PIPE5"
#define tunnel6 "PIPE6"

DFRobot_MCP23017 mcp(Wire, /*addr =*/0x27); //constructor, change the
Level of A2, A1, A0 via DIP switch to revise the I2C address within
0x20~0x27.
#define Led0 mcp.eGPB0
#define Led1 mcp.eGPB1
#define Bp0 mcp.eGPA0
#define Bp1 mcp.eGPA1

int MemLed0 =0;
int MemBp0 =0;
int tempo0 =50;

int MemLed1 =0;
int MemBp1 =0;
int tempo1 =50;

int compteur = 0;

RF24 radio(4, 5);
const byte addresses[][6] = {tunnel1, tunnel2, tunnel3, tunnel4,
tunnel5, tunnel6};
const int taille = 32;
char message[taille + 1];
char messageACK[taille +1];

void DebugVar(int nb, int valBP0) {
  Serial.print("temps = ");Serial.println(nb);
  Serial.print("Bp0 =");Serial.println(digitalRead(mcp.eGPA0));
  Serial.print("ValeurBp0 =");Serial.println(digitalRead(valBP0));
  Serial.print("MemBp0 =");Serial.println(MemBp0);
  Serial.print("MemLed0 =");Serial.println(MemLed0);
  delay(250);
}
int LectBp0() {
// Bouton 0 -- Led0

  int valeurBp0 = mcp.digitalRead(mcp.eGPA0);

//Temps 0
  if(valeurBp0== 0 && MemBp0 == 0 && MemLed0 == 0){
    mcp.digitalWrite(mcp.eGPB0, LOW); MemBp0 = 0; MemLed0 =0;

```

```
    //delay(tempo0);DebugVar(0,valeurBp0);
}
//Temps 1
if (valeurBp0 == 1 && MemBp0 ==0 && MemLed0 == 0) {
    mcp.digitalWrite(mcp.eGPB0, HIGH);MemBp0 =1;MemLed0 = 1;
    //delay(tempo0);DebugVar(1,valeurBp0);
}
//Temps 2
if (valeurBp0 == 0 && MemBp0 ==1 && MemLed0 == 1) {
    mcp.digitalWrite(mcp.eGPB0, HIGH);MemBp0 =0;MemLed0 = 1;
    //delay(tempo0);DebugVar(2,valeurBp0);
}
//Temps 3
if (valeurBp0 == 1 && MemBp0 ==0 && MemLed0 == 1) {
    mcp.digitalWrite(mcp.eGPB0, LOW);MemBp0 =1;MemLed0 = 0;
    //delay(tempo0);DebugVar(3,valeurBp0);
}
//Temps 4
if (valeurBp0 == 0 && MemBp0 ==1 && MemLed0 == 0) {
    mcp.digitalWrite(mcp.eGPB0, LOW);MemBp0 =0;MemLed0 = 0;
    //delay(tempo0);DebugVar(4,valeurBp0);
}
delay(20);
return(!valeurBp0);
}

int LectBp1(){
// Bouton 1 -- Led1

    uint8_t valeurBp1 = mcp.digitalRead(mcp.eGPA1);

//Temps 0
if(valeurBp1== 0 && MemBp1 == 0 && MemLed1 == 0){
    mcp.digitalWrite(mcp.eGPB1, LOW); MemBp1 = 0; MemLed1 =0;
    //delay(tempo0);DebugVar(0,valeurBp0);
}
//Temps 1
if (valeurBp1 == 1 && MemBp1 ==0 && MemLed1 == 0) {
    mcp.digitalWrite(mcp.eGPB1, HIGH);MemBp1 =1;MemLed1 = 1;
    //delay(tempo0);DebugVar(1,valeurBp0);
}
//Temps 2
if (valeurBp1 == 0 && MemBp1 ==1 && MemLed1 == 1) {
    mcp.digitalWrite(mcp.eGPB1, HIGH);MemBp1 =0;MemLed1 = 1;
    //delay(tempo0);DebugVar(2,valeurBp0);
}
//Temps 3
if (valeurBp1 == 1 && MemBp1 ==0 && MemLed1 == 1) {
```

```
mcp.digitalWrite(mcp.eGPB1, LOW);MemBp1 =1;MemLed1 = 0;
//delay(tempo0);DebugVar(3,valeurBp0);
}
//Temps 4
if (valeurBp1 == 0 && MemBp1 ==1 && MemLed1 == 0) {
    mcp.digitalWrite(mcp.eGPB1, LOW);MemBp1 =0;MemLed1 = 0;
    //delay(tempo0);DebugVar(4,valeurBp0);
}
return(valeurBp1);
}

void setup() {
    Serial.begin(115200);

    Serial.println("Emetteur de donnees");
    radio.begin();
    radio.setChannel(125);
    radio.setPALevel(RF24_PA_MIN);
    radio.setDataRate(RF24_250KBPS);
    radio.openWritingPipe(adresses[0]);
    //pour recevoir
    radio.openReadingPipe(1, adresses[1]);//ouverture tunnel2 en LECTURE
    (reception Radio)
    radio.openReadingPipe(2, adresses[2]);//ouverture tunnel3 en LECTURE
    (reception Radio)
    radio.openReadingPipe(3, adresses[3]);//ouverture tunnel4 en LECTURE
    (reception Radio)
    radio.openReadingPipe(4, adresses[4]);//ouverture tunnel5 en LECTURE
    (reception Radio)
    radio.openReadingPipe(5, adresses[5]);//ouverture tunnel6 en LECTURE
    (reception Radio)

    while(mcp.begin() != 0){
        Serial.println("Initialization of the chip failed, please confirm
that the chip connection is correct!");
        delay(1000);
    }

    mcp.pinMode(Bp0, INPUT);
    mcp.pinMode(Bp1, INPUT);
    mcp.pinMode(mcp.eGPB0,OUTPUT);
    mcp.pinMode(Led0,OUTPUT);
    mcp.digitalWrite(mcp.eGPB0, LOW);
    mcp.digitalWrite(Led1, LOW);
```

```
}

void loop() {

//Lecture Boutons poussoir
LectBp0();
//LectBp1();
//Serial.println(LectBp0());

compteur = LectBp0();
//Serial.println(compteur);
//delay(200);
// envoie message
if (compteur == 1 ){
  radio.stopListening();
  itoa(compteur, message, 10);
  Serial.print("J'envoie maintenant "); // pour débogage
  Serial.println(message);//Serial.print("
");Serial.println(LectBp0());
  radio.write( message, taille ); // émission du message via nRF24L01
  delay(200);
  compteur = 0;
}

radio.startListening();
if(radio.available()){

  while ( radio.available() )
  {
    radio.read( messageACK, taille );
    Serial.print("MessageACK recu : ");
    Serial.println(messageACK);
  }
  delay(20);
}
delay(5);

}
```

[ESP32_BP_NRF24L01_Reception002_GL.ino](#)

```
#include <DFRobot_MCP23017.h>

#include <SPI.h>
#include "nRF24L01.h"
#include "RF24.h"
```

```

DFRobot_MCP23017 mcp(Wire, /*addr =*/0x27); //constructor, change the
Level of A2, A1, A0 via DIP switch to revise the I2C address within
0x20~0x27.
#define Led0 mcp.eGPB0
#define Led1 mcp.eGPB1
#define Bp0 mcp.eGPA0
#define Bp1 mcp.eGPA1

int MemLed0 =0;
int MemBp0 =0;
int tempo0 =50;
int MMENTIER = 0;

int MemLed1 =0;
int MemBp1 =0;
int tempo1 =50;

int compteur = 0;

//definition tunnel de communication
#define tunnel1 "PIPE2"
#define tunnel2 "PIPE1"
#define tunnel3 "PIPE3"
#define tunnel4 "PIPE4"
#define tunnel5 "PIPE5"
#define tunnel6 "PIPE6"

RF24 radio(4, 5);
const byte adresses[][6] = {tunnel1, tunnel2, tunnel3, tunnel4,
tunnel5, tunnel6};
const int taille = 32;
char message[taille + 1];
char messageACK[taille +1];

int LectBp0(int ValMessage) {
// Bouton 0 -- Led0

//int valeurBp0 = mcp.digitalRead(mcp.eGPA0);
int valeurBp0 = ValMessage;

//Temps 0
if(valeurBp0== 0 && MemBp0 == 0 && MemLed0 == 0){
mcp.digitalWrite(mcp.eGPB0, LOW); MemBp0 = 0; MemLed0 =0;

```

```
    //delay(tempo0);DebugVar(0,valeurBp0);
}
//Temps 1
if (valeurBp0 == 1 && MemBp0 ==0 && MemLed0 == 0) {
    mcp.digitalWrite(mcp.eGPB0, HIGH);MemBp0 =1;MemLed0 = 1;
    //delay(tempo0);DebugVar(1,valeurBp0);
}
//Temps 2
if (valeurBp0 == 0 && MemBp0 ==1 && MemLed0 == 1) {
    mcp.digitalWrite(mcp.eGPB0, HIGH);MemBp0 =0;MemLed0 = 1;
    //delay(tempo0);DebugVar(2,valeurBp0);
}
//Temps 3
if (valeurBp0 == 1 && MemBp0 ==0 && MemLed0 == 1) {
    mcp.digitalWrite(mcp.eGPB0, LOW);MemBp0 =1;MemLed0 = 0;
    //delay(tempo0);DebugVar(3,valeurBp0);
}
//Temps 4
if (valeurBp0 == 0 && MemBp0 ==1 && MemLed0 == 0) {
    mcp.digitalWrite(mcp.eGPB0, LOW);MemBp0 =0;MemLed0 = 0;
    //delay(tempo0);DebugVar(4,valeurBp0);
}

return(valeurBp0);
}

int LectBp1(){
// Bouton 1 -- Led1

    uint8_t valeurBp1 = mcp.digitalRead(mcp.eGPA1);
    //uint8_t valeurBp1 = );

//Temps 0
if(valeurBp1== 0 && MemBp1 == 0 && MemLed1 == 0){
    mcp.digitalWrite(mcp.eGPB1, LOW); MemBp1 = 0; MemLed1 =0;
    //delay(tempo0);DebugVar(0,valeurBp0);
}
//Temps 1
if (valeurBp1 == 1 && MemBp1 ==0 && MemLed1 == 0) {
    mcp.digitalWrite(mcp.eGPB1, HIGH);MemBp1 =1;MemLed1 = 1;
    //delay(tempo0);DebugVar(1,valeurBp0);
}
//Temps 2
if (valeurBp1 == 0 && MemBp1 ==1 && MemLed1 == 1) {
    mcp.digitalWrite(mcp.eGPB1, HIGH);MemBp1 =0;MemLed1 = 1;
    //delay(tempo0);DebugVar(2,valeurBp0);
}
//Temps 3
if (valeurBp1 == 1 && MemBp1 ==0 && MemLed1 == 1) {
```

```
    mcp.digitalWrite(mcp.eGPB1, LOW);MemBp1 =1;MemLed1 = 0;
    //delay(tempo0);DebugVar(3,valeurBp0);
}
//Temps 4
if (valeurBp1 == 0 && MemBp1 ==1 && MemLed1 == 0) {
    mcp.digitalWrite(mcp.eGPB1, LOW);MemBp1 =0;MemLed1 = 0;
    //delay(tempo0);DebugVar(4,valeurBp0);
}
return(valeurBp1);
}

void envoiemessage1(){
    radio.stopListening();
    itoa(255,messageACK, 10);
    radio.write(messageACK, taille);
    Serial.print("messageACK1 = ");Serial.println(messageACK);
    delay(20);
    radio.startListening();
}

void envoiemessage2(){
    radio.stopListening();
    itoa(128,messageACK, 10);
    radio.write(messageACK, taille);
    Serial.print("messageACK2 = ");Serial.println(messageACK);
    delay(20);
    radio.startListening();
}

void setup() {
    Serial.begin(115200);

    Serial.println("Recepteur RF24");
    radio.begin();
    radio.setChannel(125);
    radio.setPALevel(RF24_PA_MIN);
    radio.setDataRate(RF24_250KBPS);
    radio.openWritingPipe(adresses[0]); // Ouverture tunnel1 en ECRITURE
    radio.openReadingPipe(1, adresses[1]); // Ouverture tunnel2 en
LECTURE
    radio.openReadingPipe(2, adresses[2]); // Ouverture tunnel3 en
LECTURE
    radio.openReadingPipe(3, adresses[3]); // Ouverture tunnel4 en
LECTURE
    radio.openReadingPipe(4, adresses[4]); // Ouverture tunnel5 en
LECTURE
    radio.openReadingPipe(5, adresses[5]); // Ouverture tunnel6 en
```

LECTURE

```
while(mcp.begin() != 0){
  Serial.println("Initialization of the chip failed, please confirm
that the chip connection is correct!");
  delay(1000);
}

mcp.pinMode(Bp0, INPUT);
mcp.pinMode(Bp1, INPUT);
mcp.pinMode(mcp.eGPB0, OUTPUT);
mcp.pinMode(Led0, OUTPUT);
mcp.digitalWrite(mcp.eGPB0, LOW);
mcp.digitalWrite(Led1, LOW);

}

void loop() {

//Reception Message
radio.startListening();
if (radio.available()){
while ( radio.available() )
{
  radio.read( message, taille );
  Serial.print("Message recu : ");
  Serial.println(message);
}
  delay(20);
}
delay(5);

int Mentier = atoi(message);

if ( Mentier == 0 && MMentier == 0 ) {

  message[0] = '\0'; Mentier = 0;
  mcp.digitalWrite(mcp.eGPB0, LOW);
  delay(500);
}
if ( Mentier == 1 && MMentier == 0 ) {
```

```
message[0] = '\0'; Mentier = 0;
mcp.digitalWrite(mcp.eGPB0, HIGH);
MMentier = 1;
envoiemessage1();
delay(500);
}
if ( Mentier == 1 && MMentier == 1 ) {
message[0] = '\0'; Mentier = 0;
mcp.digitalWrite(mcp.eGPB0, LOW);
MMentier = 0;
envoiemessage2();
delay(500);
}
}
```

L'achat de nrf24L01

Pas presser sur Aliexpress

Plus rapide sur Gotronic ... mais plus cher

From:

<https://www.fablab37110.chanterie37.fr/> - Castel'Lab le Fablab MJC de Château-Renault

Permanent link:

<https://www.fablab37110.chanterie37.fr/doku.php?id=start:arduino:nrf24l01&rev=1653282599>

Last update: **2023/01/27 16:08**

