

Prothese de main arduino

[Prothese main arduino 001](#)

[Capteur pour muscle Myoware](#)

[Electrodes pour muscle](#)

Main Robotisée HackBerry



[Fabrication collaborative Main-robotisée site e-nable](#)

[Doc Main robotisée](#)

[Programme main robotisée HackBerry GitHub](#)

Capteurs EMG

[Capteurs EMG c'est Quoi ? FR](#)

[EMG sur Aliexpress](#)

https://wikilab.myhumankit.org/images/a/a6/DIY_-_Faites_le_vous-m%C2%88me-_Capteur_EMG.pdf

Programme HackBerry.ino version V1.0 MK2

[HackberryMk2v1.0.ino](#)

```
/*  
 * Arduino micro code for HACKberry Mk2.  
 * Originally created by exiii Inc.  
 * edited by Kouki Shinjo on 2018/04/26  
 */
```

```
#include <Servo.h>

//Settings
const boolean isRight = 0; //right:1, left:0
const int outThumbMax = 95; //right:open, left:close
const int outIndexMax = 100; //right:open, left:close
const int outOtherMax = 75; //right:open, left:close
const int outThumbMin = 10; //right:close, left:open
const int outIndexMin = 0; //right:close, left:open
const int outOtherMin = 20; //right:close, left:open
const int speedMax = 6;
const int speedMin = 0;
const int speedReverse = -3;
const int thSpeedReverse = 15; //0-100
const int thSpeedZero = 30; //0-100
const boolean onSerial = 0; // 1 is not recommended

//Pin
int pinButtonCalib; //start calibration
int pinButtonTBD; // No function implemented yet.
int pinButtonThumb; // open/close thumb
int pinButtonOther; //lock/unlock other three fingers
int pinServoIndex;
int pinServoOther;
int pinServoThumb;
int pinSensor; //sensor input

//Hardware
Servo servoIndex; //index finger
Servo servoOther; //other three fingers
Servo servoThumb; //thumb

//Software
boolean isThumbOpen = 1;
boolean isOtherLock = 0;
int swCount0, swCount1, swCount2, swCount3 = 0;
int sensorValue = 0; // value read from the sensor
int sensorMax = 700;
int sensorMin = 0;
int speed = 0;
int position = 0;
const int positionMax = 100;
const int positionMin = 0;
int prePosition = 0;
int outThumb, outIndex, outOther = 90;
int
outThumbOpen, outThumbClose, outIndexOpen, outIndexClose, outOtherOpen, outOtherClose;

void setup() {
```

```

if (onSerial) Serial.begin(9600);

// Pin Configuration
pinButtonCalib = A6;// A4 sur Arduino Uno pour test Calibration
pinButtonTBD   = A7;// A5 sur Arduino Uno pour test
pinButtonThumb = A0;// Verrouillage pouce
pinButtonOther = 10;// Verouillage 3 doigts
pinServoIndex  = 5;// Servo pour l'index
pinServoOther  = 6;// Servo pour 3 doigts
pinServoThumb  = 9;// Servo pour le pouce
pinSensor      = A1; // Capteur de pression

if(isRight){
    outThumbOpen=outThumbMax; outThumbClose=outThumbMin;
    outIndexOpen=outIndexMax; outIndexClose=outIndexMin;
    outOtherOpen=outOtherMax; outOtherClose=outOtherMin;
} else {
    outThumbOpen=outThumbMin; outThumbClose=outThumbMax;
    outIndexOpen=outIndexMin; outIndexClose=outIndexMax;
    outOtherOpen=outOtherMin; outOtherClose=outOtherMax;
}
servoIndex.attach(pinServoIndex);//index
servoOther.attach(pinServoOther);//other
servoThumb.attach(pinServoThumb);//thumb

pinMode(pinButtonCalib, INPUT_PULLUP);
pinMode(pinButtonTBD,   INPUT_PULLUP);
pinMode(pinButtonThumb, INPUT_PULLUP);
pinMode(pinButtonOther, INPUT_PULLUP);
}

void loop() {
    //==waiting for calibration==
    if(onSerial) Serial.println("====Waiting for Calibration====");
    while (1) {
        servoIndex.write(outIndexOpen);
        servoOther.write(outOtherOpen);
        servoThumb.write(outThumbOpen);
        if(onSerial) serialMonitor();
        delay(10);
        if (readButton(pinButtonCalib) == LOW) {
            calibration();
            break;
        }
    }
    //==control==
    position = positionMin;
    prePosition = positionMin;
    while (1) {
        if (readButton(pinButtonCalib) == LOW) swCount0 += 1;
        else swCount0 = 0;
    }
}

```

```
    if (swCount0 == 10) {
        swCount0 = 0;
        calibration();
    }
    if (readButton(pinButtonTBD) == LOW) swCount1 += 1;
    else swCount1 = 0;
    if (swCount1 == 10) {
        swCount1 = 0;
        // Do something here
        while (readButton(pinButtonTBD) == LOW) delay(1);
    }
    if (readButton(pinButtonThumb) == LOW) swCount2 += 1;
    else swCount2 = 0;
    if (swCount2 == 10) {
        swCount2 = 0;
        isThumbOpen = !isThumbOpen;
        while (readButton(pinButtonThumb) == LOW) delay(1);
    }
    if (readButton(pinButtonOther) == LOW) swCount3 += 1; //A3
    else swCount3 = 0;
    if (swCount3 == 10) {
        swCount3 = 0;
        isOtherLock = !isOtherLock;
        while (readButton(pinButtonOther) == LOW) delay(1);
    }

    sensorValue = readSensor();
    delay(25);
    if(sensorValue<sensorMin) sensorValue=sensorMin;
    else if(sensorValue>sensorMax) sensorValue=sensorMax;
    sensorToPosition();

    outIndex = map(position, positionMin, positionMax,
outIndexOpen, outIndexClose);
    servoIndex.write(outIndex);
    if (!isOtherLock){
        outOther = map(position, positionMin, positionMax,
outOtherOpen, outOtherClose);
        servoOther.write(outOther);
    }
    if(isThumbOpen) servoThumb.write(outThumbOpen);
    else servoThumb.write(outThumbClose);
    if(onSerial) serialMonitor();
}

/*
 * functions
 */
boolean isDigitalPin(const int pin) {
```

```
    return (pin >= 0) && (pin <= 19) ? true : false;
}

boolean readButton(const int pin) {
    if ( isDigitalPin(pin) ) {
        return digitalRead(pin);
    } else {
        if (analogRead(pin) > 512) return HIGH;
        else return LOW;
    }
}

int readSensor() {
    int i, sval;
    for (i = 0; i < 10; i++) {
        sval += analogRead(pinSensor);
    }
    sval = sval/10;
    return sval;
}

void sensorToPosition(){
    int tmpVal = map(sensorValue, sensorMin, sensorMax, 100, 0);
    if(tmpVal<thSpeedReverse) speed=speedReverse;
    else if(tmpVal<thSpeedZero) speed=speedMin;
    else speed=map(tmpVal,40,100,speedMin,speedMax);
    position = prePosition + speed;
    if (position < positionMin) position = positionMin;
    if (position > positionMax) position = positionMax;
    prePosition = position;
}

void calibration() {
    outIndex=outIndexOpen;
    servoIndex.write(outIndexOpen);
    servoOther.write(outOtherClose);
    servoThumb.write(outThumbOpen);
    position=positionMin;
    prePosition=positionMin;

    delay(200);
    if(onSerial) Serial.println("=====calibration start=====");

    sensorMax = readSensor();
    sensorMin = sensorMax - 50;
    unsigned long time = millis();
    while ( millis() < time + 4000 ) {
        sensorValue = readSensor();
        delay(25);
        if ( sensorValue < sensorMin ) sensorMin = sensorValue;
        else if ( sensorValue > sensorMax )sensorMax = sensorValue;
    }
}
```

```
        sensorToPosition();
        outIndex = map(position, positionMin, positionMax,
outIndexOpen, outIndexClose);
        servoIndex.write(outIndex);

        if(onSerial) serialMonitor();
    }
    if(onSerial) Serial.println("=====calibration finish=====");
    return;
}

void serialMonitor(){
    Serial.print("Min="); Serial.print(sensorMin);
    Serial.print(",Max="); Serial.print(sensorMax);
    Serial.print(",sensor="); Serial.print(sensorValue);
    Serial.print(",speed="); Serial.print(speed);
    Serial.print(",position="); Serial.print(position);
    Serial.print(",outIndex="); Serial.print(outIndex);
    Serial.print(",isThumbOpen="); Serial.print(isThumbOpen);
    Serial.print(",isOtherLock="); Serial.println(isOtherLock);
}
```

Programme HackBerry.ino version V3.1 MK2

[Hackberrv31MK2_V31.ino](#)

```
/*
 * Arduino micro code for HACKberry.
 * Originally created by exiii Inc.
 * edited by Genta Kondo on 2017/6/11
 */
#include <Servo.h>

//Settings
const boolean isRight = 1;//right:1, left:0

//For right hand, find optimal values of ThumbMin, IndexMax and
OtherMax first.
//For left hand, find optimal values of ThumbMax, IndexMin and OtherMin
first.
//Then, calculate the remaining values by following rules.
//Difference of ThumbMin and ThumbMax is 86
//Difference of IndexMin and IndexMax is 117
//Difference of OtherMin and OtherMax is 55

const int outThumbMax = 170;//right:open, left:close
const int outIndexMax = 142;//right:open, left:close
```

```
const int outOtherMax = 96; //right:open, left:close

const int outThumbMin = 170-86; //right:close, left:open
const int outIndexMin = 140-117; //right:close, left:open
const int outOtherMin = 95-55; //right:close, left:open

const int speedMax = 6;
const int speedMin = 0;
const int speedReverse = -3;
const int thSpeedReverse = 15; //0-100
const int thSpeedZero = 30; //0-100
const boolean onSerial = 0; //Mk2 doesn't use serial monitor

//Hardware
Servo servoIndex; //index finger
Servo servoOther; //other three fingers
Servo servoThumb; //thumb
int pinCalib; //start calibration
//int pinTBD;
int pinThumb; // open/close thumb
int pinOther; //lock/unlock other three fingers
int pinSensor = A1; //sensor input

//Software
boolean isThumbOpen = 1;
boolean isOtherLock = 0;
int swCount0, swCount1, swCount2, swCount3 = 0;
int sensorValue = 0; // value read from the sensor
int sensorMax = 700;
int sensorMin = 0;
int speed = 0;
int position = 0;
const int positionMax = 100;
const int positionMin = 0;
int prePosition = 0;
int outThumb, outIndex, outOther = 90;
int
outThumbOpen, outThumbClose, outIndexOpen, outIndexClose, outOtherOpen, outOtherClose;

void setup() {
  Serial.begin(9600);
  if(isRight){
    pinCalib = A6;
    //pinTBD = A7;
    pinThumb = A0;
    pinOther = 10;
    outThumbOpen=outThumbMax; outThumbClose=outThumbMin;
    outIndexOpen=outIndexMax; outIndexClose=outIndexMin;
    outOtherOpen=outOtherMax; outOtherClose=outOtherMin;
  }
}
```

```
else{
  pinCalib = A6;
  //pinTBD = A7;
  pinThumb = A0;
  pinOther = 10;
  outThumbOpen=outThumbMin; outThumbClose=outThumbMax;
  outIndexOpen=outIndexMin; outIndexClose=outIndexMax;
  outOtherOpen=outOtherMin; outOtherClose=outOtherMax;
}
servoIndex.attach(5);//index
servoOther.attach(6);//other
servoThumb.attach(9);//thumb
//pinMode(pinCalib, INPUT);//A6
//digitalWrite(pinCalib, HIGH);
//pinMode(pinTBD, INPUT);//A5
//digitalWrite(pinTBD, HIGH);
pinMode(pinThumb, INPUT);//A4
digitalWrite(pinThumb, HIGH);
pinMode(pinOther, INPUT);//A3
digitalWrite(pinOther, HIGH);
}

void loop() {
  //==waiting for calibration==
  if(onSerial) Serial.println("====Waiting for Calibration====");
  while (1) {
    servoIndex.write(outIndexOpen);
    servoOther.write(outOtherOpen);
    servoThumb.write(outThumbOpen);
    if(onSerial) serialMonitor();
    delay(10);
    if (DigitalRead(pinCalib) == LOW) {
      calibration();
      break;
    }
  }
  //==control==
  position = positionMin;
  prePosition = positionMin;
  while (1) {
    if (DigitalRead(pinCalib) == LOW) swCount0 += 1;
    else swCount0 = 0;
    if (swCount0 == 10) {
      swCount0 = 0;
      calibration();
    }
    if (digitalRead(pinThumb) == LOW) swCount2 += 1;
    else swCount2 = 0;
    if (swCount2 == 10) {
      swCount2 = 0;
    }
  }
}
```

```

    isThumbOpen = !isThumbOpen;
    while (digitalRead(pinThumb) == LOW) delay(1);
}
if (digitalRead(pinOther) == LOW) swCount3 += 1;//A3
else swCount3 = 0;
if (swCount3 == 10) {
    swCount3 = 0;
    isOtherLock = !isOtherLock;
    while (digitalRead(pinOther) == LOW) delay(1);
}

sensorValue = readSensor();
delay(25);
if(sensorValue<sensorMin) sensorValue=sensorMin;
else if(sensorValue>sensorMax) sensorValue=sensorMax;
sensorToPosition();

outIndex = map(position, positionMin, positionMax, outIndexOpen,
outIndexClose);
servoIndex.write(outIndex);
if (!isOtherLock){
    outOther = map(position, positionMin, positionMax, outOtherOpen,
outOtherClose);
    servoOther.write(outOther);
}
if(isThumbOpen) servoThumb.write(outThumbOpen);
else servoThumb.write(outThumbClose);
if(onSerial) serialMonitor();
}
}

/*
 * functions
 */
int readSensor() {
    int i, sval;
    for (i = 0; i < 10; i++) {
        sval += analogRead(pinSensor);
    }
    sval = sval/10;
    return sval;
}

void sensorToPosition(){
    int tmpVal = map(sensorValue, sensorMin, sensorMax, 100, 0);
    if(tmpVal<thSpeedReverse) speed=speedReverse;
    else if(tmpVal<thSpeedZero) speed=speedMin;
    else speed=map(tmpVal,40,100,speedMin,speedMax);
    position = prePosition + speed;
    if (position < positionMin) position = positionMin;
    if (position > positionMax) position = positionMax;
}

```

```
prePosition = position;
}

void calibration() {
  outIndex=outIndexOpen;
  servoIndex.write(outIndexOpen);
  servoOther.write(outOtherClose);
  servoThumb.write(outThumbOpen);
  position=positionMin;
  prePosition=positionMin;

  delay(200);
  if(onSerial) Serial.println("=====calibration start=====");

  sensorMax = readSensor();
  sensorMin = sensorMax - 50;
  unsigned long time = millis();
  while ( millis() < time + 4000 ) {
    sensorValue = readSensor();
    delay(25);
    if ( sensorValue < sensorMin ) sensorMin = sensorValue;
    else if ( sensorValue > sensorMax ) sensorMax = sensorValue;

    sensorToPosition();
    outIndex = map(position, positionMin, positionMax, outIndexOpen,
outIndexClose);
    servoIndex.write(outIndex);

    if(onSerial) serialMonitor();
  }
  if(onSerial) Serial.println("=====calibration finish=====");
}

void serialMonitor(){
  Serial.print("Min="); Serial.print(sensorMin);
  Serial.print(",Max="); Serial.print(sensorMax);
  Serial.print(",sensor="); Serial.print(sensorValue);
  Serial.print(",speed="); Serial.print(speed);
  Serial.print(",position="); Serial.print(position);
  Serial.print(",outIndex="); Serial.print(outIndex);
  Serial.print(",isThumbOpen="); Serial.print(isThumbOpen);
  Serial.print(",isOtherLock="); Serial.println(isOtherLock);
}

boolean DigitalRead(const int pin) {
  if (analogRead(pin) > 512) return 1;
  else return 0;
}
```

Simulation main sur Tinkercad

Cablage Arduino Uno et servoMoteurs

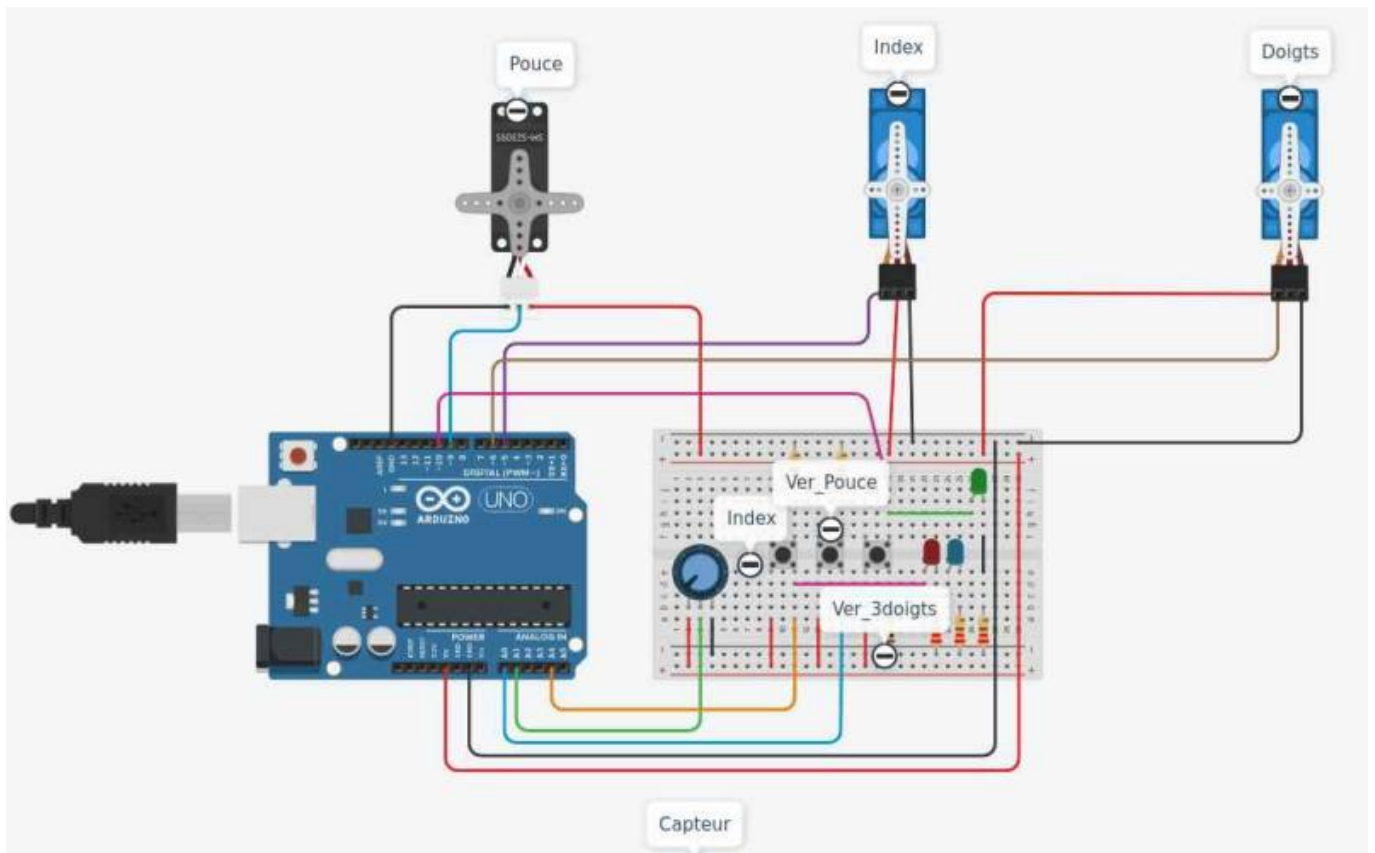

Schema



Programme HackBerry_Test_tinkercad.ino version V1.0

[Main_robot_0011.ino](#)

```
#include <Servo.h>

//Pin
int pinButtonCalib; //start calibration
int pinButtonTBD; // No function implemented yet.
int pinButtonThumb; // open/close thumb
int pinButtonOther; //lock/unlock other three fingers
int pinServoIndex;
int pinServoOther;
int pinServoThumb;
int pinSensor; //sensor input

//Software
int sensorValue = 0;
int memPouce = 0;
int memIndex = 0;
int mem3Dgts = 0;

//Hardware
Servo servoIndex; //index
Servo servoOther; //3doigts
```

```
Servo servoThumb; //pouce

//Valeurs mini/max servos
const int outThumbMax = 170; //valeur max servo pouce
const int outIndexMax = 142; //valeur max servo index
const int outOtherMax = 96; //valeur max servo 3doigts

const int outThumbMin = 170-86; //valeur min servo pouce 170-86=84
const int outIndexMin = 140-117; //valeur min servo index 140-117= 23
const int outOtherMin = 95-55; //valeur min servo 3doigts 95-55 = 40

void setup() {
  Serial.begin(9600);

  // Pin Configuration
  pinButtonCalib = A4; // A6 sur Hackberry pour test Calibration --
  validation index
  pinButtonTBD = A5; // A7 sur Hackberry pour test
  pinButtonThumb = A0; // Verrouillage pouce -- validation pouce
  pinButtonOther = 10; // Verrouillage 3 doigts -- validation 3doigts
  pinServoIndex = 5; // Servo pour l'index
  pinServoOther = 6; // Servo pour 3 doigts
  pinServoThumb = 9; // Servo pour le pouce
  pinSensor = A1; // Capteur de pression

  servoIndex.attach(pinServoIndex); //index
  servoOther.attach(pinServoOther); // 3 doigts
  servoThumb.attach(pinServoThumb); //Pouce
  pinMode(pinButtonCalib, INPUT_PULLUP);
  pinMode(pinButtonTBD, INPUT_PULLUP);
  pinMode(pinButtonThumb, INPUT_PULLUP);
  pinMode(pinButtonOther, INPUT_PULLUP);
}

void loop() {
  sensorValue = 0;

  if ( digitalRead(pinButtonThumb) == HIGH ){
    memPouce = 1;
    memIndex = 0;
    mem3Dgts = 0;
  }
  if ( digitalRead(pinButtonCalib) == HIGH ){
    memPouce = 0;
    mem3Dgts = 0;
    memIndex = 1;
  }
  if ( digitalRead(pinButtonOther) == HIGH ){
    memPouce = 0;
    mem3Dgts = 1;
    memIndex = 0;
  }
}
```

```
}  
  
if (memPouce == 1){  
  sensorValue = analogRead(pinSensor);  
  delay(25);  
  sensorValue = map(sensorValue, 0, 1023, outThumbMin, outThumbMax);  
  Serial.print("sensor pouce= "); Serial.println(sensorValue);  
  servoThumb.write(sensorValue);  
  delay(15);  
}  
if (memIndex == 1){  
  sensorValue = analogRead(pinSensor);  
  delay(25);  
  sensorValue = map(sensorValue, 0, 1023, outIndexMin, outIndexMax);  
  Serial.print("sensor index= "); Serial.println(sensorValue);  
  servoIndex.write(sensorValue);  
  delay(15);  
}  
if (mem3Dgts == 1){  
  sensorValue = analogRead(pinSensor);  
  delay(25);  
  sensorValue = map(sensorValue, 0, 1023, outOtherMin, outOtherMax);  
  Serial.print("sensor doigts= "); Serial.println(sensorValue);  
  servoOther.write(sensorValue);  
  delay(15);  
}  
}
```

From:
<https://www.fablab37110.chanterie37.fr/> - **Castel'Lab le Fablab MJC de Château-Renault**

Permanent link:
<https://www.fablab37110.chanterie37.fr/doku.php?id=start:arduino:mains&rev=1669053299>

Last update: **2023/01/27 16:08**

